

■ **INTRODUCTION**

The HG1202 is a CMOS PFM-control step-up switching DC/DC converter. The PFM controller allows the duty ratio to be automatically switched according to the load, enabling products with a low ripple over a wide range, high efficiency, and high output current. With the HG1202, a step-up switching DC/DC converter can be configured by using an external coil, capacitor, and diode. The built-in MOSFET is turned off by a protection circuit when the voltage at the LX pin exceeds the limit to prevent it from being damaged. This feature, along with the mini package and low current consumption, makes the HG1202 ideal for applications such as the power supply unit of portable equipment.

■ **FEATURES**

- Low voltage operation: Startup at 0.9 V @ I_{OUT} = 1 mA
- Working frequency: 300KHz
- External parts: Coil, capacitor, diode
- Accuracy of ±2%
- High efficiency: 87% (typ.)
- Shutdown function
- Low ripple, Low noise

■ **APPLICATIONS**

- Digital cameras
- Electronic notebooks and PDAs
- Portable CD/MD players
- Cameras, video equipment,
- Communications equipment
- Power supply for microcomputers

■ **BLOCK DIAGRAM**

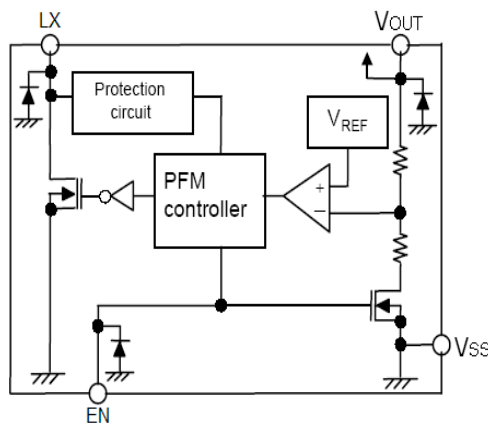

■ **ORDER INFORMATION**

● **HG1202①②③④**

DESIGNATOR	SYMBOL	DESCRIPTION
①	A	Standard LX
	B	Standard EXT
	C	With shutdown, LX
	D	With shutdown, EXT
②③	Integer	Output Voltage (1.8~6.0) e.g.: 3.0V=②:3; ③:0
④	M	Package: SOT-23
	P	Package: SOT-89
	T	Package: TO-92

■ PIN CONFIGURATION

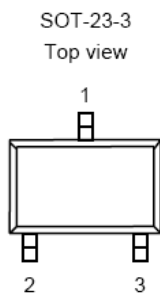

Table 1 HG1202A Series (SOT-23-3 PKG)

PIN NO.	PIN NAME	FUNCTION
1	V_{OUT}	Output voltage pin
2	V_{SS}	GND pin
3	LX	External inductor connection pin

Table 2 HG1202B Series (SOT-23-3 PKG)

PIN NO.	PIN NAME	FUNCTION
1	V_{OUT}	Output voltage pin
2	V_{SS}	GND pin
3	EXT	External transistor connection pin

Table 3 HG1202C Series (SOT-23-5 PKG)

PIN NO.	PIN NAME	FUNCTION
1	EN	Shutdown pin “H”: Normal operation “L”: Step-up stopped
2	V_{OUT}	Output voltage pin
3	NC	(N.C.)
4	V_{SS}	GND pin
5	LX	External inductor connection pin

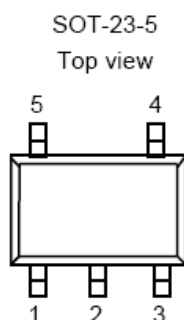

Table 4 HG1202D Series (SOT-23-5 PKG)

PIN NO.	PIN NAME	FUNCTION
1	EN	Shutdown pin “H”: Normal operation “L”: Step-up stopped
2	V_{OUT}	Output voltage pin
3	NC	(N.C.)
4	V_{SS}	GND pin
5	EXT	External transistor connection pin

Table 5 HG1202A Series (SOT-89-3 PKG)

PIN NO.	PIN NAME	FUNCTION
1	V_{SS}	GND pin
2	V_{OUT}	Output voltage pin
3	LX	External inductor connection pin

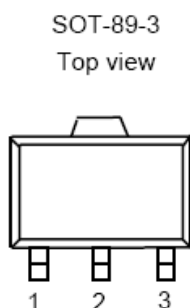

Table 6 HG1202B Series (SOT-89-3 PKG)

PIN NO.	PIN NAME	FUNCTION
1	V_{SS}	GND pin
2	V_{OUT}	Output voltage pin
3	EXT	External transistor connection pin

Table 7 HG1202C Series (SOT-89-5 PKG)

PIN NO.	PIN NAME	FUNCTION
1	NC	(N.C.)
2	V _{OUT}	Output voltage pin
3	EN	Shutdown pin “H”: Normal operation “L”: Step-up stopped
4	LX	External inductor connection pin
5	V _{SS}	GND pin

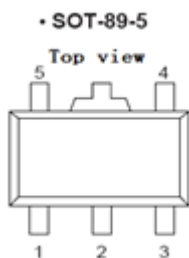
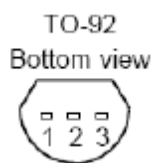

Table 8 HG1202D Series (SOT-89-5 PKG)

PIN NO.	PIN NAME	FUNCTION
1	NC	(N.C.)
2	V _{OUT}	Output voltage pin
3	EN	Shutdown pin “H”: Normal operation “L”: Step-up stopped
4	EXT	External transistor connection pin
5	V _{SS}	GND pin

Table 9 HG1202A Series (TO-92 PKG)



PIN NO.	PIN NAME	FUNCTION
1	V _{SS}	GND pin
2	V _{OUT}	Output voltage pin
3	LX	External inductor connection pin

■ ABSOLUTE MAXIMUM RATINGS

(Unless otherwise specified, Ta=□25°C)

PARAMETER	SYMBOL	RATINGS	UNITS
V _{OUT} pin voltage	V _{OUT}	V _{SS} -0.3 ~ V _{SS} +8	V
EN pin voltage	EN	V _{SS} -0.3 ~ V _{SS} +8	V
LX pin voltage	V _{LX}	V _{SS} -0.3 ~ V _{SS} +8	V
LX pin current	I _{LX}	1500	mA
Power dissipation	PD	250	mW
Operating temperature	T _{opr}	-20 ~+85	°C
Storage temperature	T _{stg}	-40 ~+125	°C
Soldering Temperature & Time	T _{solder}	260°C, 10s	

■ ELECTRICAL CHARACTERISTICS

(Unless otherwise specified, Ta=25°C)

PARAMETER	SYMBOL	CONDITIONS	MIN	TYP	MAX	UNITS
Output voltage	V_{OUT}	—	$V_{OUT(S)} \times 0.98$	V_{OUT}	$V_{OUT(S)} \times 1.02$	V
Input voltage	V_{IN}	—	—	—	6	V
Operation start voltage	V_{ST}	$I_{OUT} = 1 \text{ mA}$	—	—	0.9	V
Hold voltage	V_{HOLD}	$I_{OUT} = 1 \text{ mA}$	0.8	—	—	V
Current consumption	I_{SS}	$V_{OUT} = V_{OUT(S)} + 0.5 \text{ V}$	—	7	—	μA
Current consumption during shutdown	I_{SSS}	$V_{EN} = 0 \text{ V}$, No load	—	—	1.0	μA
Maximum Oscillation frequency	F_{max}	$V_{OUT} = 0.95 \times V_{OUT}$, measure waveform at LX pin	—	300	—	KHz
Duty ratio	Duty		—	75	—	%
Efficiency	EFFI		—	87	—	%
Current limit	I_{LIMIT}		—	1000	—	mA
Shutdown pin input voltage	V_{SH}		1.5	—	—	V
	V_{SL}		—	—	0.3	V
Shutdown pin input current	I_{SH}		—	—	0.1	μA
	I_{SL}		-0.1	—	—	μA

Remark: $V_{IN} = V_{OUT(S)} \times 0.6$ applied, $I_{OUT} = V_{OUT(S)} / 250 \Omega$

$V_{OUT(S)}$ specified above is the set output voltage value, and V_{OUT} is the typical value of the actual output voltage.

■ STANDARD CIRCUITS

1、HG1202A Circuits:

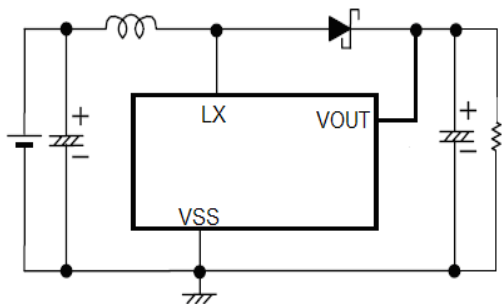

2、HG1202C Circuits:

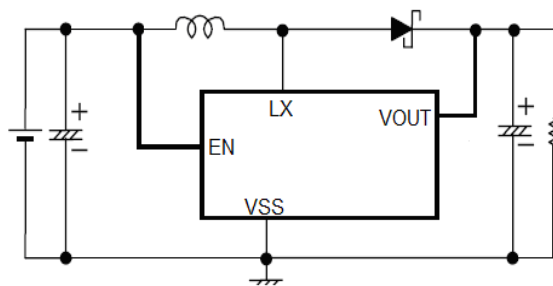

3、HG1202B Circuits:

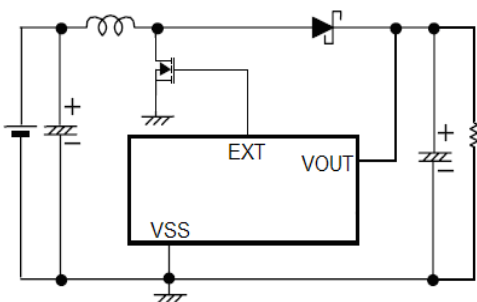

4、HG1202D Circuits:

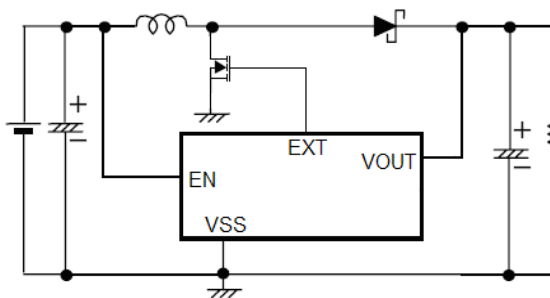

■ TYPICAL PERFORMANCE CHARACTERISTICS

HG1202A50P:

a、 V_{OUT} vs. I_{OUT} :

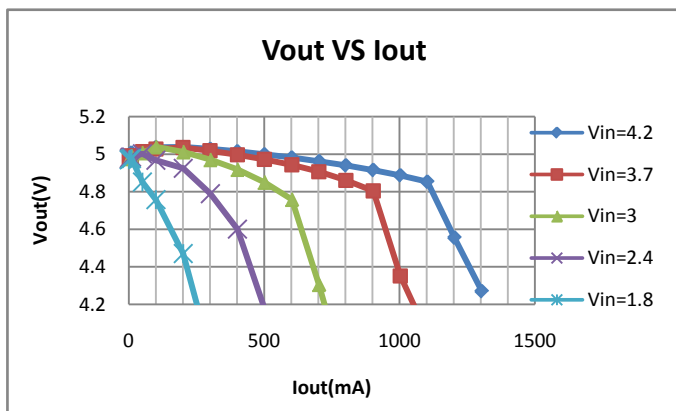

b、Efficiency vs. I_{OUT} :

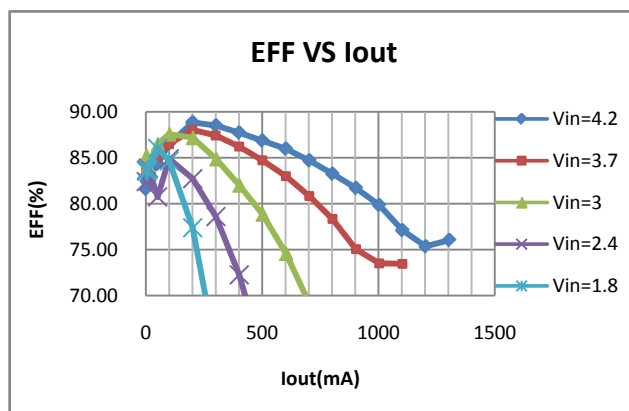

HG1202B50P:

a、 V_{OUT} vs. I_{OUT} :

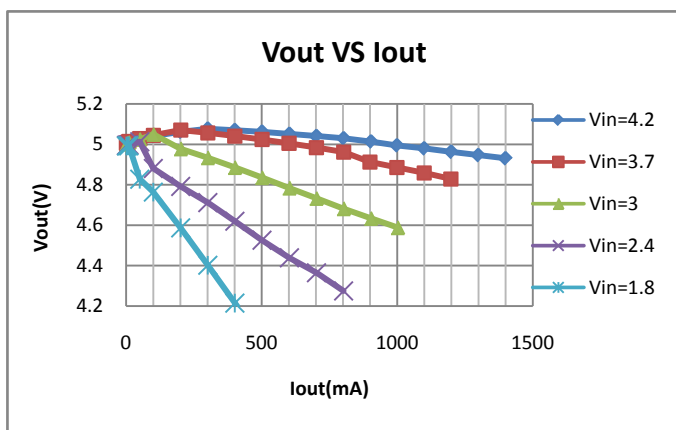

b、Efficiency vs. I_{OUT} :

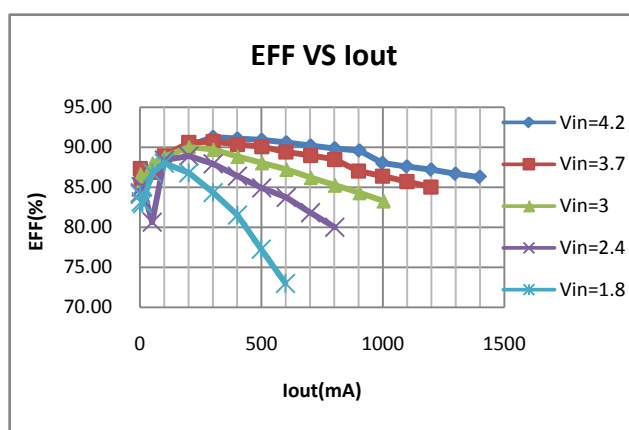

■ PACKAGE INFORMATION

● SOT-23-3

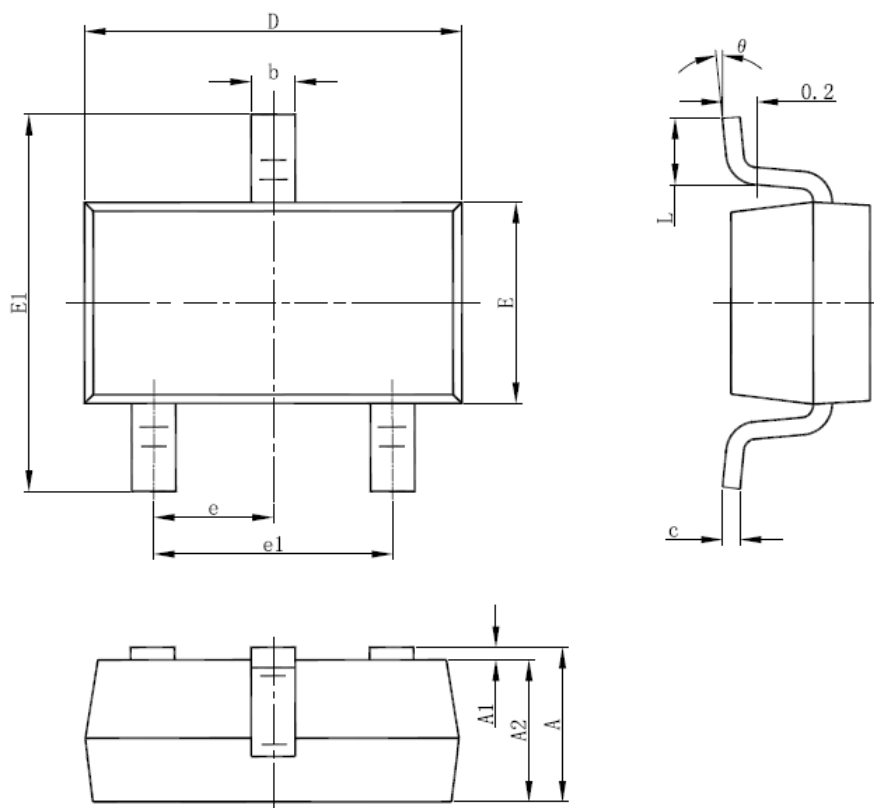

Symbol	Dimensions In Millimeters		Dimensions In Inches	
	Min	Max	Min	Max
A	1.050	1.250	0.041	0.049
A1	0.000	0.100	0.000	0.004
A2	1.050	1.150	0.041	0.045
b	0.300	0.500	0.012	0.020
c	0.100	0.200	0.004	0.008
D	2.820	3.020	0.111	0.119
E	1.500	1.700	0.059	0.067
E1	2.650	2.950	0.104	0.116
e	0.950(BSC)		0.037(BSC)	
e1	1.800	2.000	0.071	0.079
L	0.300	0.600	0.012	0.024
θ	0°	8°	0°	8°

• SOT-23-5

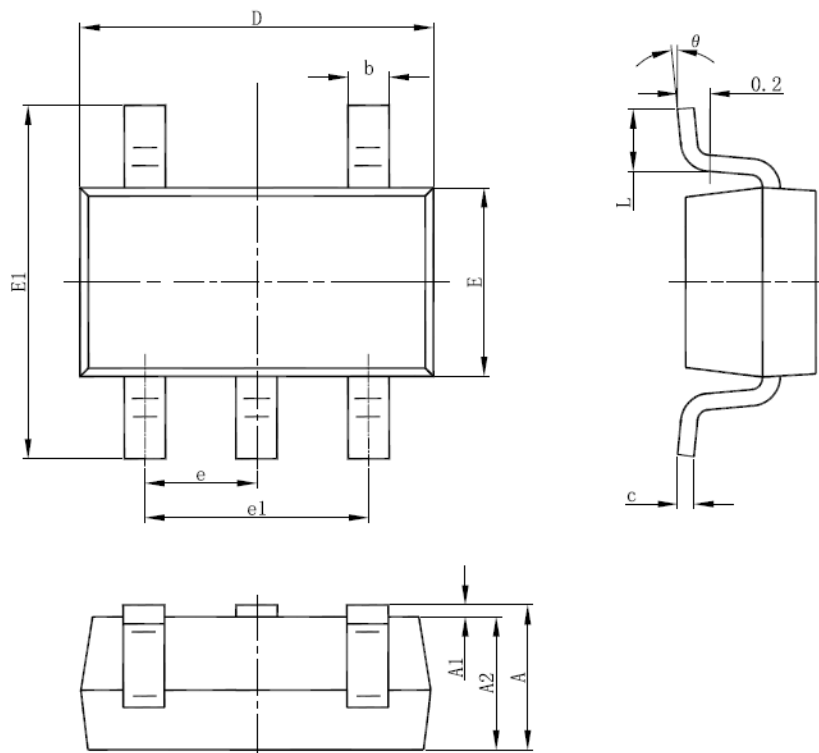

Symbol	Dimensions In Millimeters		Dimensions In Inches	
	Min	Max	Min	Max
A	1.050	1.250	0.041	0.049
A1	0.000	0.100	0.000	0.004
A2	1.050	1.150	0.041	0.045
b	0.300	0.500	0.012	0.020
c	0.100	0.200	0.004	0.008
D	2.820	3.020	0.111	0.119
E	1.500	1.700	0.059	0.067
E1	2.650	2.950	0.104	0.116
e	0.950(BSC)		0.037(BSC)	
e1	1.800	2.000	0.071	0.079
L	0.300	0.600	0.012	0.024
θ	0°	8°	0°	8°

• SOT-89-3

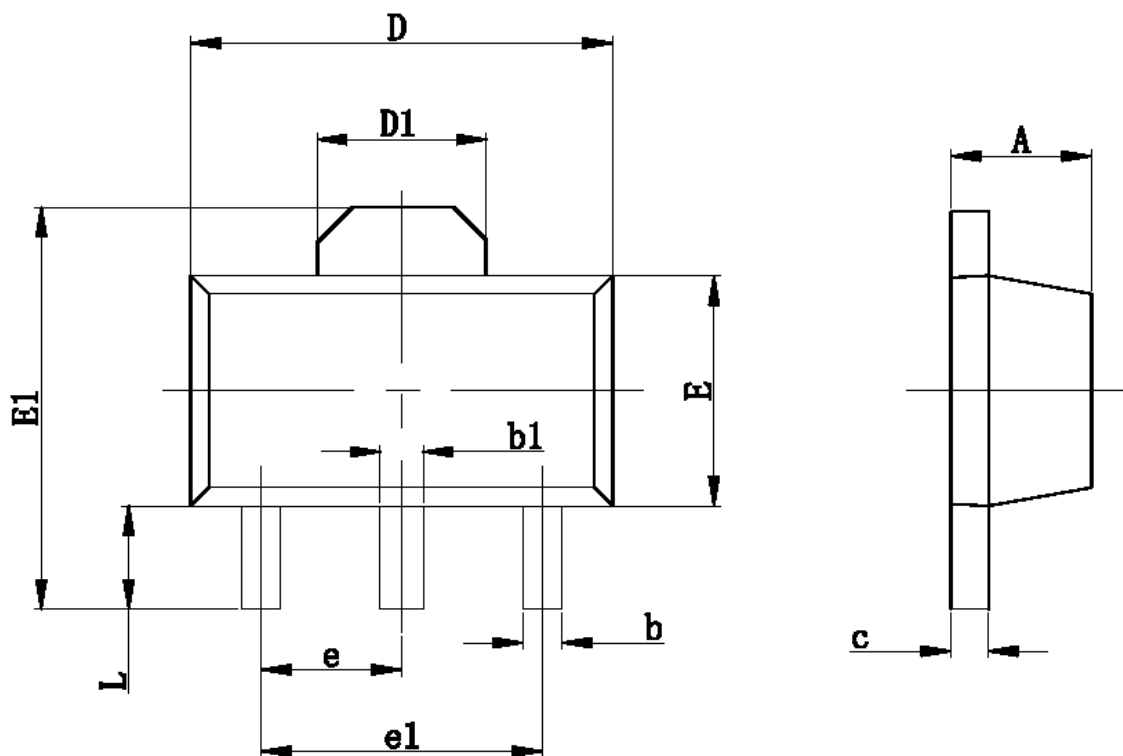

Symbol	Dimensions In Millimeters		Dimensions In Inches	
	Min	Max	Min	Max
A	1.400	1.600	0.055	0.063
b	0.320	0.520	0.013	0.197
b1	0.400	0.580	0.016	0.023
c	0.350	0.440	0.014	0.017
D	4.400	4.600	0.173	0.181
D1	1.550 REF		0.061 REF	
E	2.300	2.600	0.091	0.102
E1	3.940	4.250	0.155	0.167
e	1.500 TYP		0.060TYP	
e1	3.000 TYP		0.118TYP	
L	0.900	1.200	0.035	0.047

• SOT-89-5

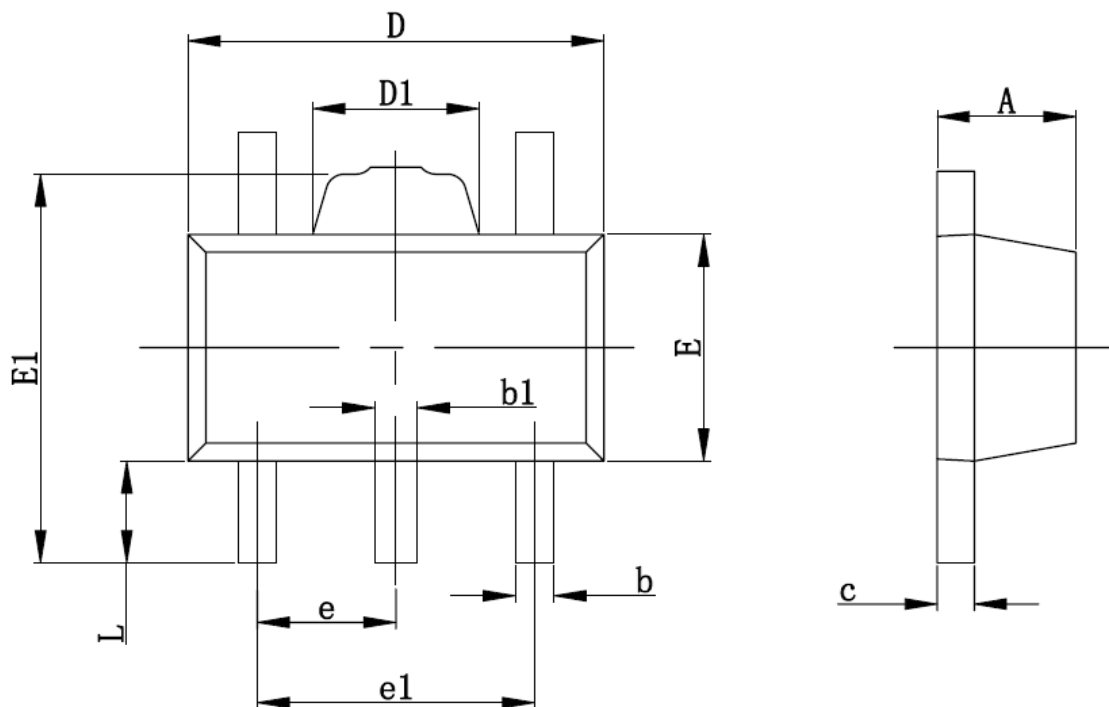

Symbol	Dimensions In Millimeters		Dimensions In Inches	
	Min	Max	Min	Max
A	1.400	1.600	0.055	0.063
b	0.320	0.520	0.013	0.020
b1	0.360	0.560	0.014	0.022
c	0.350	0.440	0.014	0.017
D	4.400	4.600	0.173	0.181
D1	1.400	1.800	0.055	0.071
E	2.300	2.600	0.091	0.102
E1	3.940	4.250	0.155	0.167
e	1.500TYP		0.060TYP	
e1	2.900	3.100	0.114	0.122
L	0.900	1.100	0.035	0.043

- TO-92

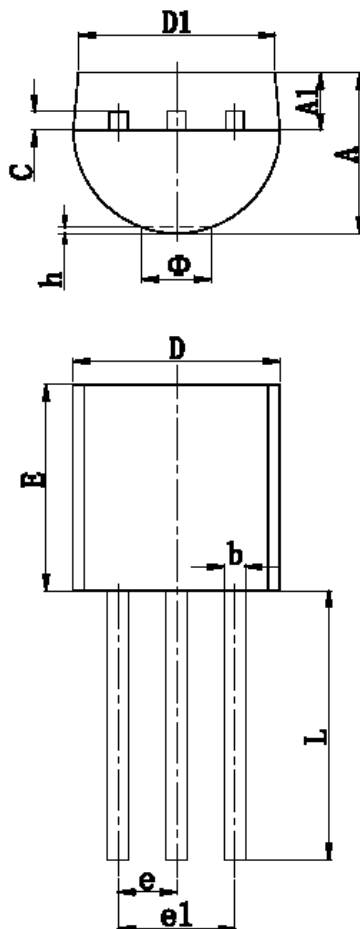

Symbol	Dimensions In Millimeters		Dimensions In Inches	
	Min	Max	Min	Max
A	3.300	3.700	0.130	0.146
A1	1.100	1.400	0.043	0.055
b	0.380	0.550	0.015	0.022
c	0.360	0.510	0.014	0.020
D	4.400	4.700	0.173	0.185
D1	3.430		0.135	
E	4.300	4.700	0.169	0.185
e	1.270 TYP		0.050 TYP	
e1	2.440	2.640	0.096	0.104
L	14.100	14.500	0.555	0.571
Φ		1.600		0.063
h	0.000	0.380	0.000	0.015