

**N-Channel Enhancement Mode Power MOSFET**

● **Features**

$V_{DS}$	$R_{DS(ON)TYP}$	$I_D$
100V	100 mΩ@10V	3.4A
	110mΩ@4.5V	

● **General Description**

- low side switch in SMPS
- general purpose applications

● **Pin Configurations**

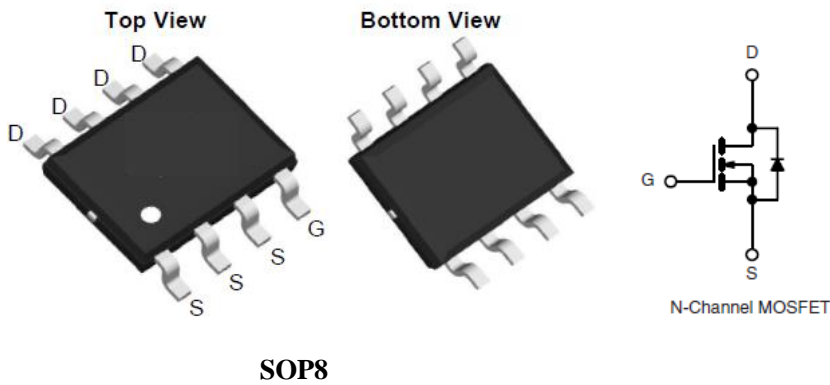

● **Absolute Maximum Ratings @ $T_A=25^{\circ}C$  unless otherwise noted**

Parameter		Symbol	Ratings	Unit
Drain-Source Voltage		$V_{DSS}$	100	V
Gate-Source Voltage		$V_{GSS}$	$\pm 20$	V
Drain Current (Continuous) *AC	$T_A=25^{\circ}C$	$I_D$	3.4	A
	$T_A=70^{\circ}C$		2.7	
Drain Current (Pulse) *B		$I_{DM}$	13.6	A
Power Dissipation	$T_A=25^{\circ}C$	$P_D$	2.5	W
Operating Temperature/ Storage Temperature		$T_J/T_{STG}$	-55~150	$^{\circ}C$

● **Thermal Resistance Ratings**

Parameter		Symbol	Max	Unit
Maximum Junction-to-Ambient	$t \leq 10s$	$R_{thJA}$	50	$^{\circ}C/W$

## Electrical Characteristics

$T_A=25^\circ\text{C}$  unless otherwise noted

Parameter	Symbol	Test Conditions	Min	Typ	Max	Unit
<b>Static</b>						
Drain-Source Breakdown Voltage	$V_{(BR)DSS}$	$V_{GS} = 0V, I_D = 250\mu A$	100	--	--	V
Zero Gate Voltage Drain Current	$I_{DSS}$	$V_{DS} = 100V, V_{GS} = 0V$	--	--	1	$\mu A$
Gate Threshold Voltage	$V_{GS(TH)}$	$V_{GS} = V_{DS}, I_{DS} = 250\mu A$	1	1.75	2.5	V
Gate Leakage Current	$I_{GSS}$	$V_{GS} = \pm 20V, V_{DS} = 0V$	--	--	$\pm 100$	nA
Drain-Source On-state Resistance	$R_{DS(on)}$	$V_{GS} = 10V, I_D = 1.7A$	--	100	130	m $\Omega$
	$R_{DS(on)}$	$V_{GS} = 4.5V, I_D = 1A$	--	110	140	m $\Omega$
Diode Forward Voltage	$V_{SD}$	$I_{SD} = 1A, V_{GS} = 0V$	--	--	1.2	V
Diode Forward Current *AC	$I_S$	$T_A = 25^\circ\text{C}$	--	--	3.4	A
<b>Switching</b>						
Total Gate Charge	$Q_g$	$V_{DS} = 80V, I_D = 3.4A,$ $V_{GS} = 10V$	--	12	--	nC
Gate-Source Charge	$Q_{gs}$		--	2.5	--	nC
Gate-Drain Charge	$Q_{gd}$		--	4.2	--	nC
Turn-on Delay Time	$t_{d(on)}$	$V_{DD} = 50V, I_D = 3.4A,$ $V_{GS} = 10V, R_{GEN} = 25\Omega$	--	14	--	ns
Turn-on Rise Time	$t_r$		--	3	--	ns
Turn-off Delay Time	$t_{d(off)}$		--	38	--	ns
Turn-Off Fall Time	$t_f$		--	7.5	--	ns
<b>Dynamic</b>						
Input Capacitance	$C_{iss}$	$V_{DS} = 25V, V_{GS} = 0V, f = 1.0\text{MHz}$	--	540	--	pF
Output Capacitance	$C_{oss}$		--	100	--	pF
Reverse Transfer Capacitance	$C_{rss}$		--	22	--	pF

A: The value of  $R_{\theta JA}$  is measured with the device mounted on 1in<sup>2</sup> FR-4 board with 2oz. Copper, in a still air environment with  $T_A=25^\circ\text{C}$ . The value in any given application depends on the user's specific board design.

B: Repetitive rating, pulse width limited by junction temperature.

C: The current rating is based on the  $t_s \leq 10\text{s}$  junction to ambient thermal resistance rating.

# Typical Electrical and Thermal Characteristics

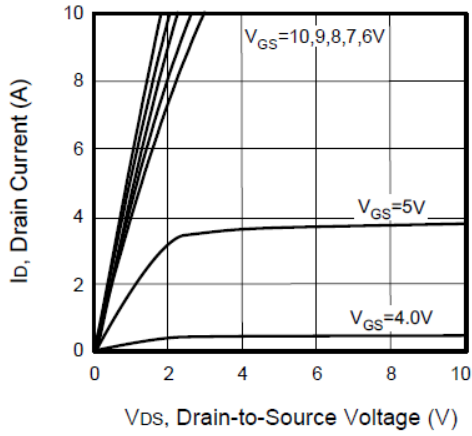

Figure 1. Output Characteristics

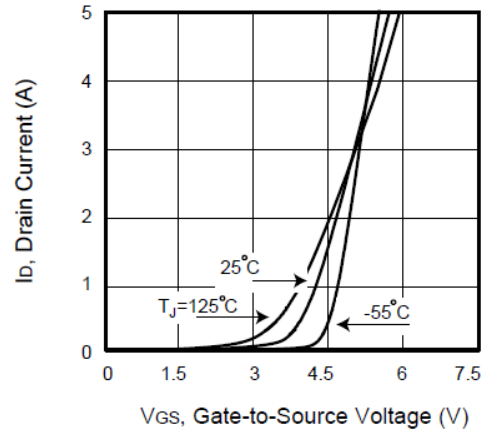

Figure 2. Transfer Characteristics

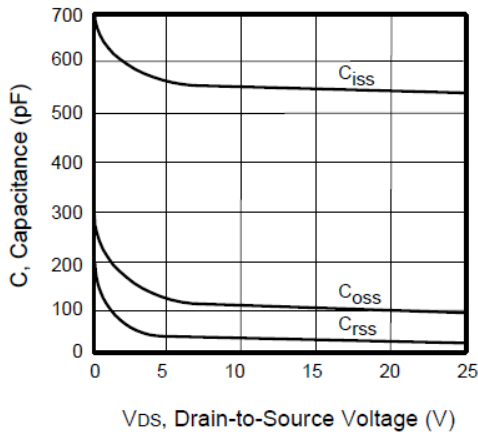

Figure 3. Capacitance

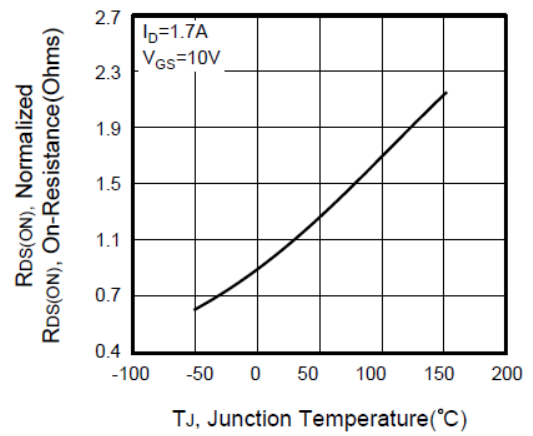

Figure 4. On-Resistance Variation with Temperature

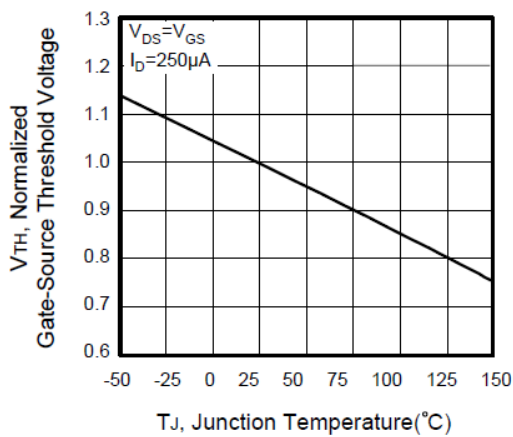

Figure 5. Gate Threshold Variation with Temperature

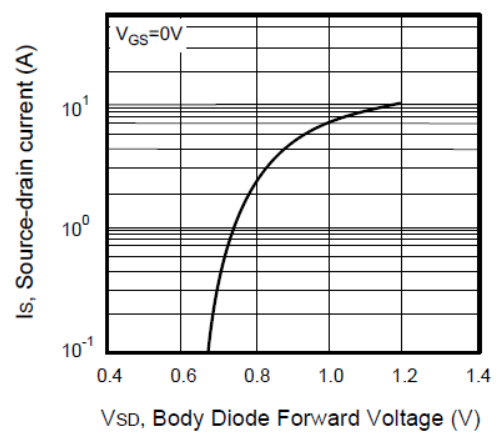

Figure 6. Body Diode Forward Voltage Variation with Source Current

# Typical Electrical and Thermal Characteristics

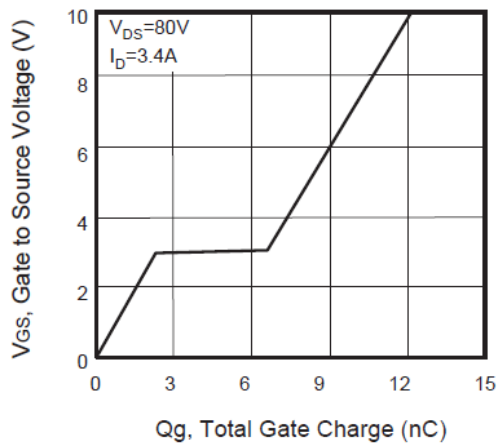

Figure 7. Gate Charge

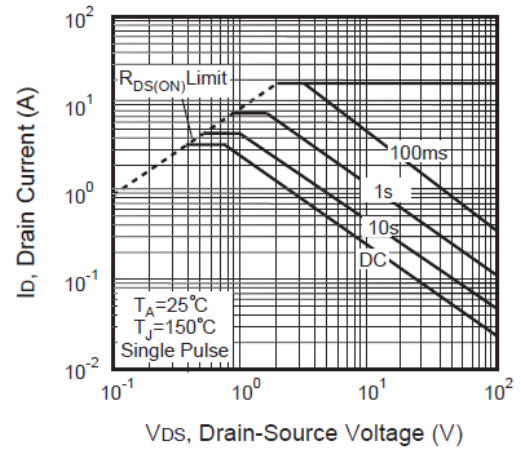

Figure 8. Maximum Safe Operating Area

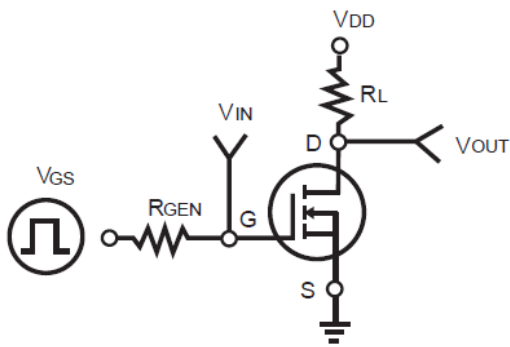

Figure 9. Switching Test Circuit

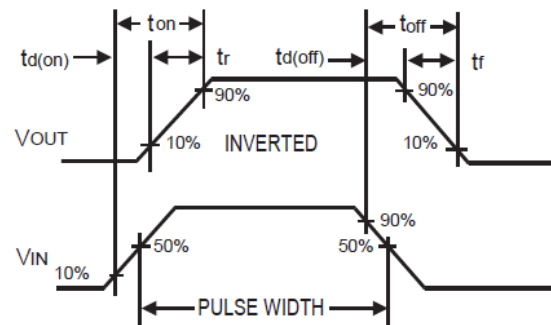

Figure 10. Switching Waveforms

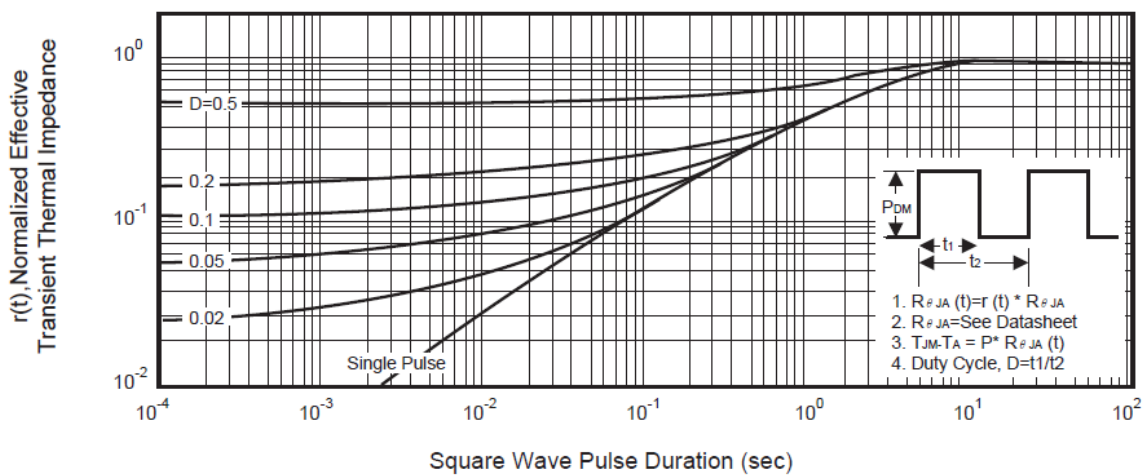
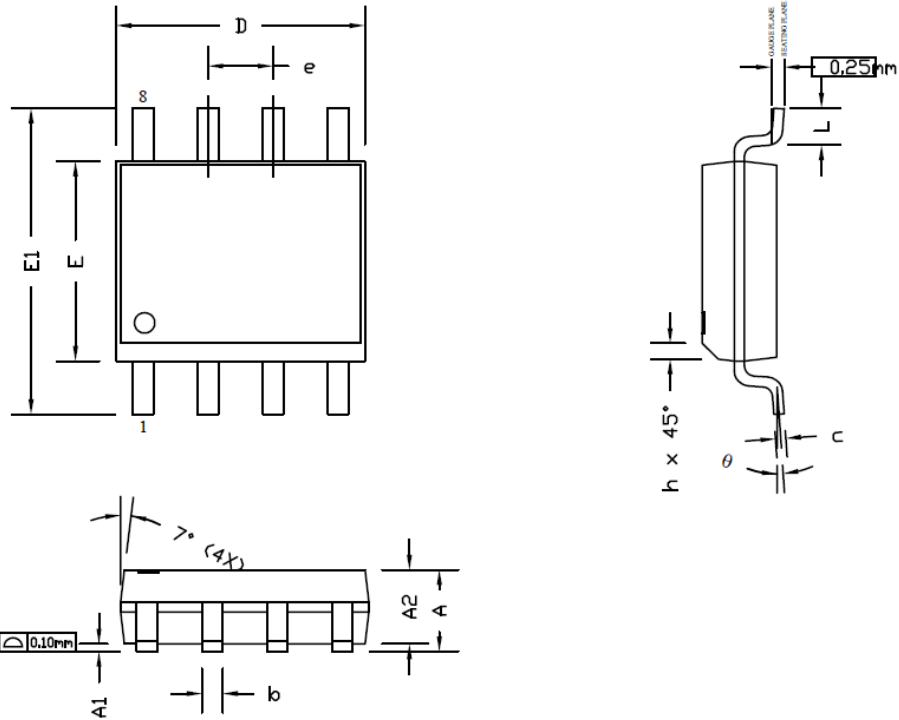
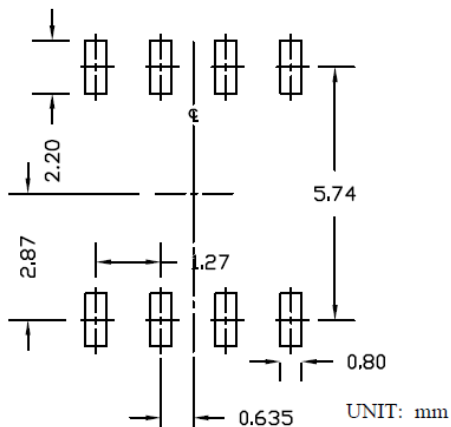

Figure 11. Normalized Thermal Transient Impedance Curve

# Package Information



## RECOMMENDED LAND PATTERN



SYMBOLS	DIMENSIONS IN MILLIMETERS			DIMENSIONS IN INCHES		
	MIN	NOM	MAX	MIN	NOM	MAX
A	1.35	1.65	1.75	0.053	0.065	0.069
A1	0.10	0.15	0.25	0.004	0.006	0.010
A2	1.25	1.50	1.65	0.049	0.059	0.065
b	0.31	0.41	0.51	0.012	0.016	0.020
c	0.17	0.20	0.25	0.007	0.008	0.010
D	4.80	4.90	5.00	0.189	0.193	0.197
E	3.80	3.90	4.00	0.150	0.154	0.157
e	1.27 BSC			0.050 BSC		
E1	5.80	6.00	6.20	0.228	0.236	0.244
h	0.25	0.30	0.50	0.010	0.012	0.020
L	0.40	0.69	1.27	0.016	0.027	0.050
θ	0°	4°	8°	0°	4°	8°

### NOTE

1. ALL DIMENSIONS ARE IN MILLIMETERS.
2. DIMENSIONS ARE INCLUSIVE OF PLATING.
3. PACKAGE BODY SIZES EXCLUDE MOLD FLASH AND GATE BURRS.  
MOLD FLASH AT THE NON-LEAD SIDES SHOULD BE LESS THAN 6 MILS EACH.
4. DIMENSION L IS MEASURED IN GAUGE PLANE.
5. CONTROLLING DIMENSION IS MILLIMETER.  
CONVERTED INCH DIMENSIONS ARE NOT NECESSARILY EXACT.