

■ INTRODUCTION

The HG1201 Series is a CMOS PFM-control step-up switching DC/DC converter. The PFM controller allows the duty ratio to be automatically switched according to the load (light load: 66%, high output current: 78%), enabling products with a low ripple over a wide range, high efficiency, and high output current. With the HG1201 Series a step-up switching DC/DC converter can be configured by using an external coil, capacitor, and diode. The built-in MOSFET is turned off by a protection circuit when the voltage at the LX pin exceeds the limit to prevent it from being damaged. This feature, along with the mini package and low current consumption, makes the HG1201 Series ideal for applications such as the power supply unit of portable equipment.

■ FEATURES

- Low voltage operation: Startup at 0.9 V min. ($I_{OUT} = 1 \text{ mA}$) guaranteed
- Duty ratio: 66/78%, built in auto switching type PFM controller
- External parts: Coil, capacitor, diode
- Output voltage: Settable to between 1.8V to 6.0 V in 0.1 V steps
- Accuracy of $\pm 2\%$
- High efficiency: $\pm 85\%$ (typ.)
- Standard function (product type A)
- Shutdown function (product type C,D)
- External transistor type available (product type B、D)

■ APPLICATIONS

- Digital cameras
- Electronic notebooks and PDAs
- Portable CD/MD players
- Cameras, video equipment,
- Communications equipment
- Power supply for microcomputers

■ BLOCK DIAGRAM

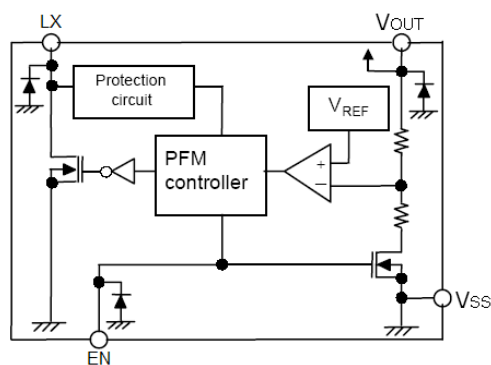

■ ORDER INFORMATION

HG1201 ①②③④

DESIGNATOR	SYMBOL	DESCRIPTION
①	A	Standard LX
	B	Standard EXT
	C	With shutdown, LX
	D	With shutdown, EXT
②③	Integer	Output Voltage (1.8~6.0) e.g.: 3.0V=②:3; ③:0
④	M	Package: SOT-23
	P	Package: SOT-89
	T	Package: TO-92

■ PIN CONFIGURATION

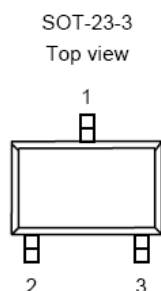

Table 1 HG1201A Series (SOT-23-3 PKG)

PIN NO.	PIN NAME	FUNCTION
1	V_{OUT}	Output voltage pin
2	V_{SS}	GND pin
3	LX	External inductor connection pin

Table 2 HG1201B Series (SOT-23-3 PKG)

PIN NO.	PIN NAME	FUNCTION
1	V_{OUT}	Output voltage pin
2	V_{SS}	GND pin
3	EXT	External transistor connection pin

Table 3 HG1201C Series (SOT-23-5 PKG)

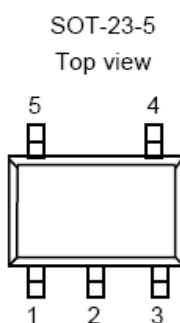

PIN NO.	PIN NAME	FUNCTION
1	EN	Shutdown pin “H”: Normal operation “L”: Step-up stopped
2	V_{OUT}	Output voltage pin
3	NC	(N.C.)
4	V_{SS}	GND pin
5	LX	External inductor connection pin

Table 4 HG1201D Series (SOT-23-5 PKG)

PIN NO.	PIN NAME	FUNCTION
1	EN	Shutdown pin “H”: Normal operation “L”: Step-up stopped
2	V_{OUT}	Output voltage pin
3	NC	(N.C.)
4	V_{SS}	GND pin
5	EXT	External transistor connection pin

Table 5 HG1201A Series (SOT-89-3 PKG)

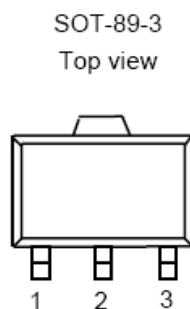

PIN NO.	PIN NAME	FUNCTION
1	V_{SS}	GND pin
2	V_{OUT}	Output voltage pin
3	LX	External inductor connection pin

Table 6 HG1201B Series (SOT-89-3 PKG)

PIN NO.	PIN NAME	FUNCTION
1	V_{SS}	GND pin
2	V_{OUT}	Output voltage pin
3	EXT	External transistor connection pin

Table 7 HG1201C Series (SOT-89-5 PKG)

PIN NO.	PIN NAME	FUNCTION
1	NC	(N.C.)
2	V _{OUT}	Output voltage pin
3	EN	Shutdown pin “H”: Normal operation “L”: Step-up stopped
4	LX	External inductor connection pin
5	V _{SS}	GND pin

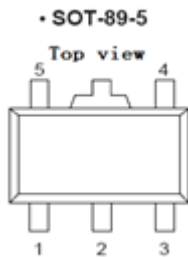

Table 8 HG1201D Series (SOT-89-5 PKG)

PIN NO.	PIN NAME	FUNCTION
1	NC	(N.C.)
2	V _{OUT}	Output voltage pin
3	EN	Shutdown pin “H”: Normal operation “L”: Step-up stopped
4	EXT	External transistor connection pin
5	V _{SS}	GND pin



Table 9 HG1201A Series (TO-92 PKG)

PIN NO.	PIN NAME	FUNCTION
1	V _{SS}	GND pin
2	V _{OUT}	Output voltage pin
3	LX	External inductor connection pin

■ ABSOLUTE MAXIMUM RATINGS

(Unless otherwise specified, T_a=25°C)

PARAMETER		SYMBOL	RATINGS	UNITS
V _{OUT} pin voltage		V _{OUT}	V _{SS} -0.3 ~ V _{SS} +8	V
EN pin voltage		EN	V _{SS} -0.3 ~ V _{SS} +8	V
LX pin voltage		V _{LX}	V _{SS} -0.3 ~ V _{SS} +8	V
LX pin current		I _{LX}	1000	mA
Power dissipation	SOT-23-3	PD	250	mW
	SOT-23-5		250	mW
	SOT-89-3		500	mW
	TO-92		500	mW
Operating temperature		T _{opr}	-40 ~+85	°C
Storage temperature		T _{stg}	-40 ~+125	°C
Soldering Temperature & Time		T _{solder}	260°C, 10s	

■ ELECTRICAL CHARACTERISTICS

(Unless otherwise specified, $T_a=25^\circ\text{C}$)

PARAMETER	SYMBOL	CONDITIONS	MIN	TYP	MAX	UNITS	
Output voltage	V_{OUT}	—	$V_{OUT(S)} \times 0.98$	V_{OUT}	$V_{OUT(S)} \times 1.02$	V	
Input voltage	V_{IN}	—	—	—	6	V	
Operation start voltage	V_{ST1}	$I_{OUT} = 1 \text{ mA}$	—	—	0.9	V	
Oscillation start voltage	V_{ST2}	No external parts, voltage applied to V_{OUT} LX pulled up to V_{OUT} via 300Ω resistor	—	—	0.8	V	
Current consumption 1	I_{SS1}	$V_{OUT} = 0.95 \times V_{OUT}$	$V_{OUT}: 3.0\text{V}$	—	20	40	μA
			$V_{OUT}: 5.0\text{V}$	—	30	60	μA
Current consumption 2	I_{SS2}	$V_{OUT} = V_{OUT} + 0.5 \text{ V}$	—	6	10	μA	
Current consumption during shutdown	I_{SSS}	$V_{EN} = 0 \text{ V}$	—	—	1.0	μA	
Switching current	I_{SW}	$V_{LX} = 0.4 \text{ V}$	100	200	—	mA	
Switching transistor leakage current	I_{SWQ}	No external parts, $V_{LX} = V_{OUT} = 8 \text{ V}$, $V_{EN} = 0 \text{ V}$	—	—	1.0	μA	
Line regulation	ΔV_{OUT1}	$V_{IN} = 0.4 \times V_{OUT} \sim 0.6 \times V_{OUT}$	—	20	50	mV	
Load regulation	ΔV_{OUT2}	$I_{OUT} = 10 \mu\text{A} \sim 50\text{mA}$	—	20	50	mV	
Maximum Oscillation frequency	f_{OSC}	$V_{OUT} = 0.95 \times V_{OUT}$, measure waveform at LX pin	—	100	—	KHz	
Duty ratio 1	Duty1	$V_{OUT} = 0.95 \times V_{OUT}$, measure waveform at LX pin	70	78	85	%	
Duty ratio 2	Duty2	Measure waveform at LX pin with light load	—	66	—	%	
Efficiency	EFF1	—	—	85	—	%	
Shutdown pin input voltage	V_{SH}	$V_{OUT} = 0.95 \times V_{OUT}$, judge oscillation at LX pin	0.75	—	—	V	
	V_{SL1}	$V_{OUT} = 0.95 \times V_{OUT}$, judge stop at LX pin	—	—	0.3	V	
Shutdown pin input current	I_{SH}	$V_{EN} = 6\text{V}$	-0.1	—	0.1	μA	
	I_{SL}	$V_{EN} = 0\text{V}$	-0.1	—	0.1	μA	

Remark: $V_{IN} = V_{OUT(S)} \times 0.6$ applied, $I_{OUT} = V_{OUT(S)} / 250 \Omega$

Shutdown function built-in type: EN pin is connected to V_{OUT}

V_{ST1} only is suitable for HG1201

$V_{OUT(S)}$ specified above is the set output voltage value, and V_{OUT} is the typical value of the actual output voltage.

■ STANDARD CIRCUITS

Component: Inductor: 47uH(Sumida)
 Capacitor: 47uF/16V(Tantalum)
 NMOS: XP151、XP161

Diode: IN5817、IN5819
 Transistor: 2SD1628G、2SD3279
 Base Resistor(Rb): 1K Ω

1、HG1201A Circuits:

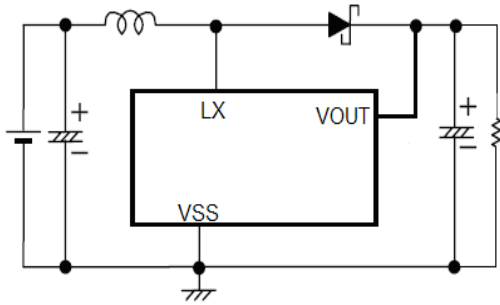

2、HG1201C Circuits:

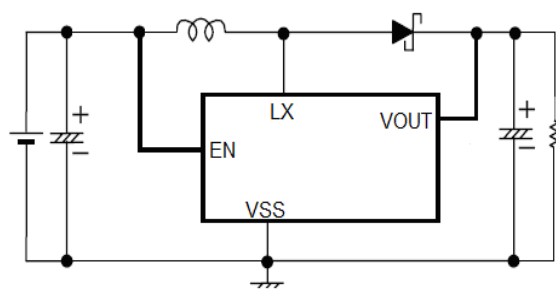

3、HG1201B Circuits:

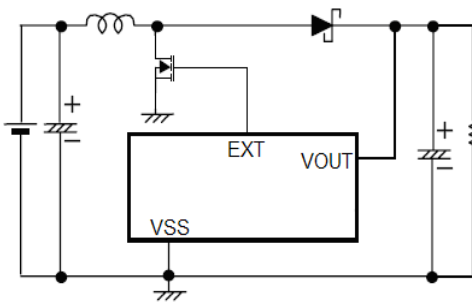

4、HG1201D Circuits:

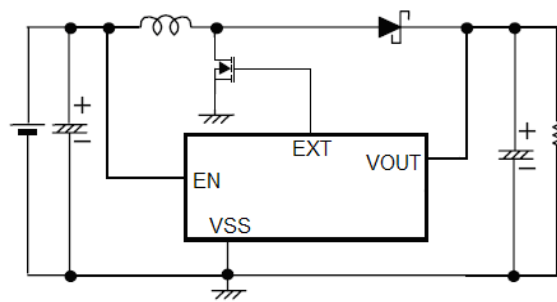

■ TYPICAL PERFORMANCE CHARACTERISTICS

1.HG1201A30P :

a、 V_{OUT} vs. I_{OUT} :

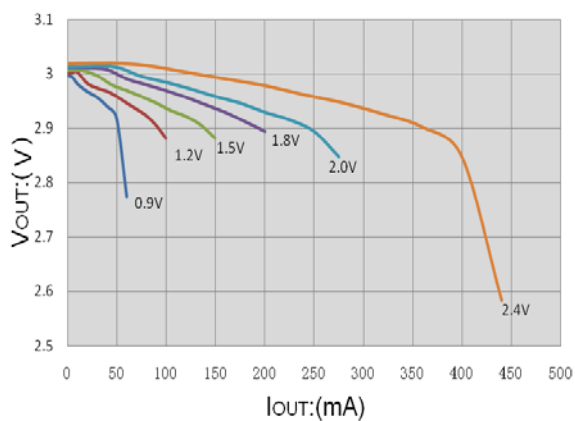

b、Efficiency vs. I_{OUT} :

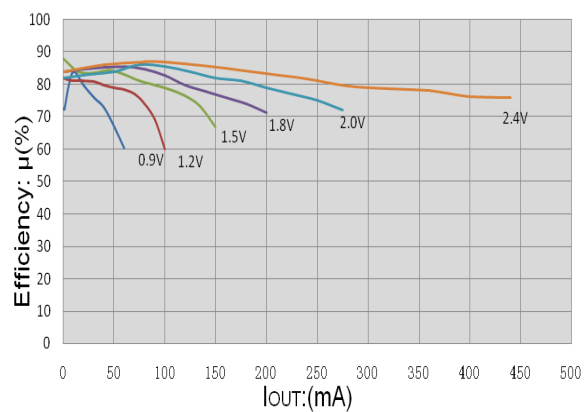

2. HG1201A33P:

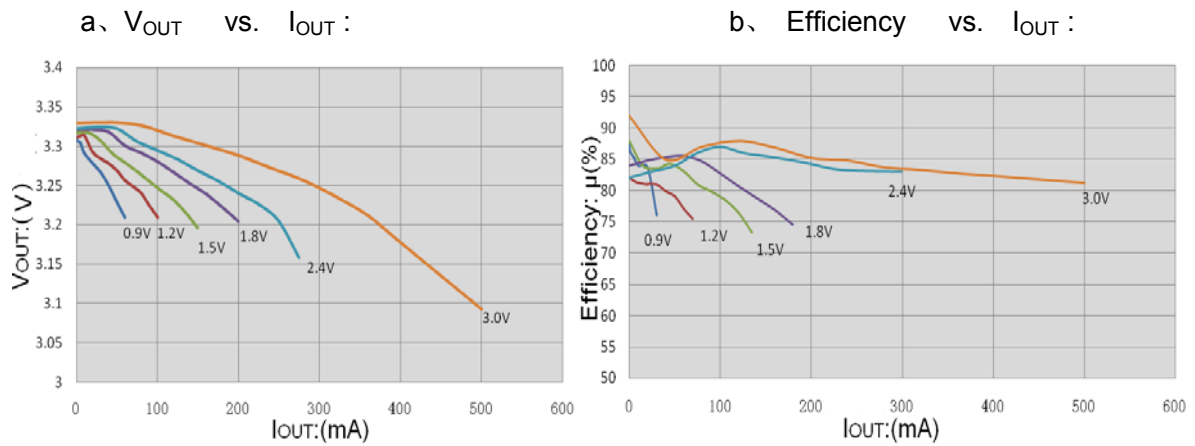

3. HG1201A50P:

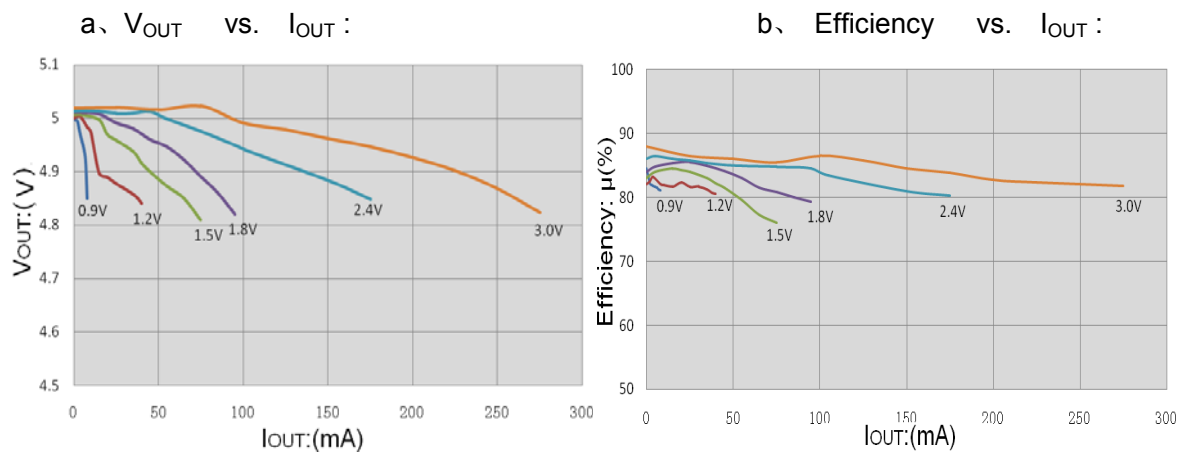

4. HG1201B36P:

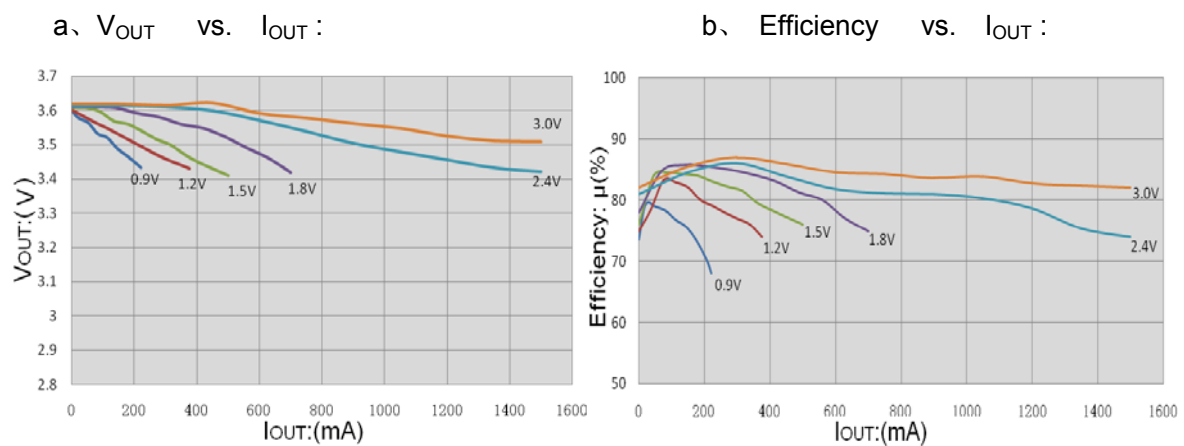

5. HG1201B50P:

a、 V_{OUT} vs. I_{OUT} :

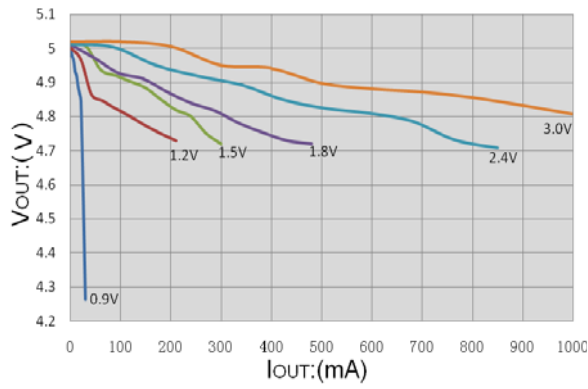

b、Efficiency vs. I_{OUT} :

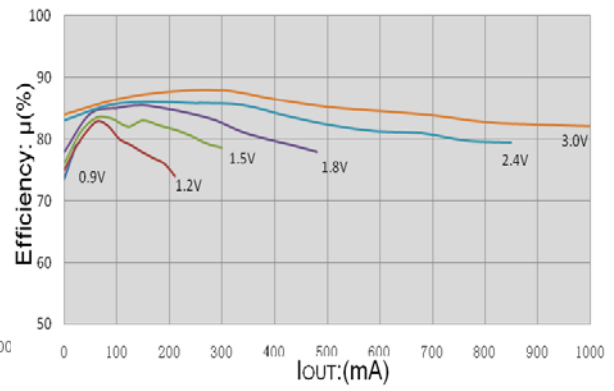

■ PACKAGE INFORMATION

● SOT-23-3

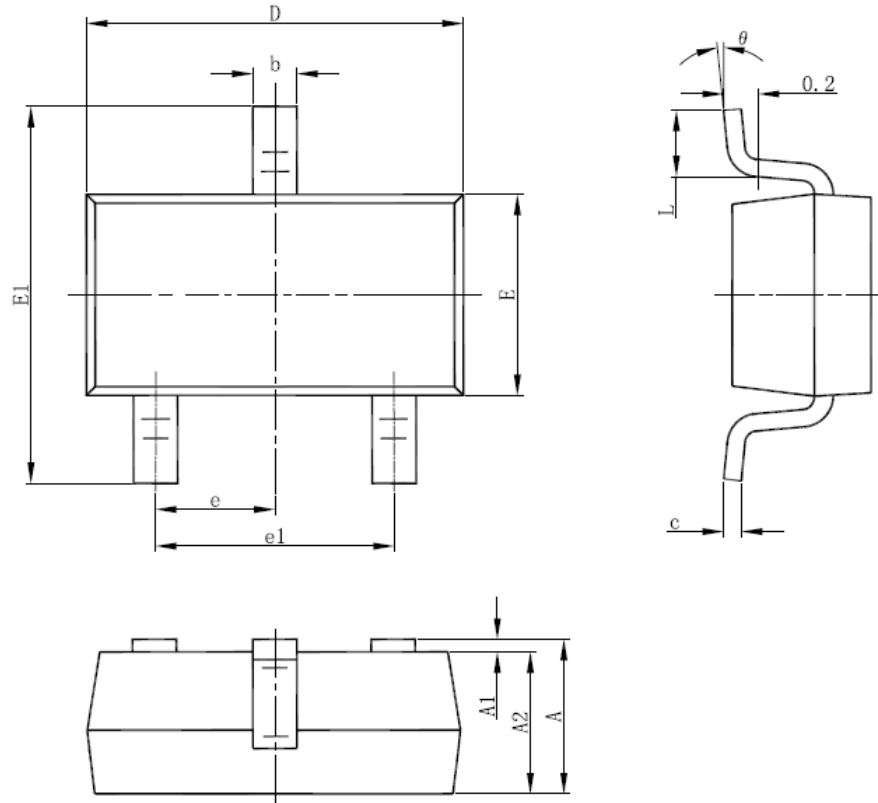

Symbol	Dimensions In Millimeters		Dimensions In Inches	
	Min	Max	Min	Max
A	1.050	1.250	0.041	0.049
A1	0.000	0.100	0.000	0.004
A2	1.050	1.150	0.041	0.045
b	0.300	0.500	0.012	0.020
c	0.100	0.200	0.004	0.008
D	2.820	3.020	0.111	0.119
E	1.500	1.700	0.059	0.067
E1	2.650	2.950	0.104	0.116
e	0.950(BSC)		0.037(BSC)	
e1	1.800	2.000	0.071	0.079
L	0.300	0.600	0.012	0.024
θ	0°	8°	0°	8°

• SOT-89-3

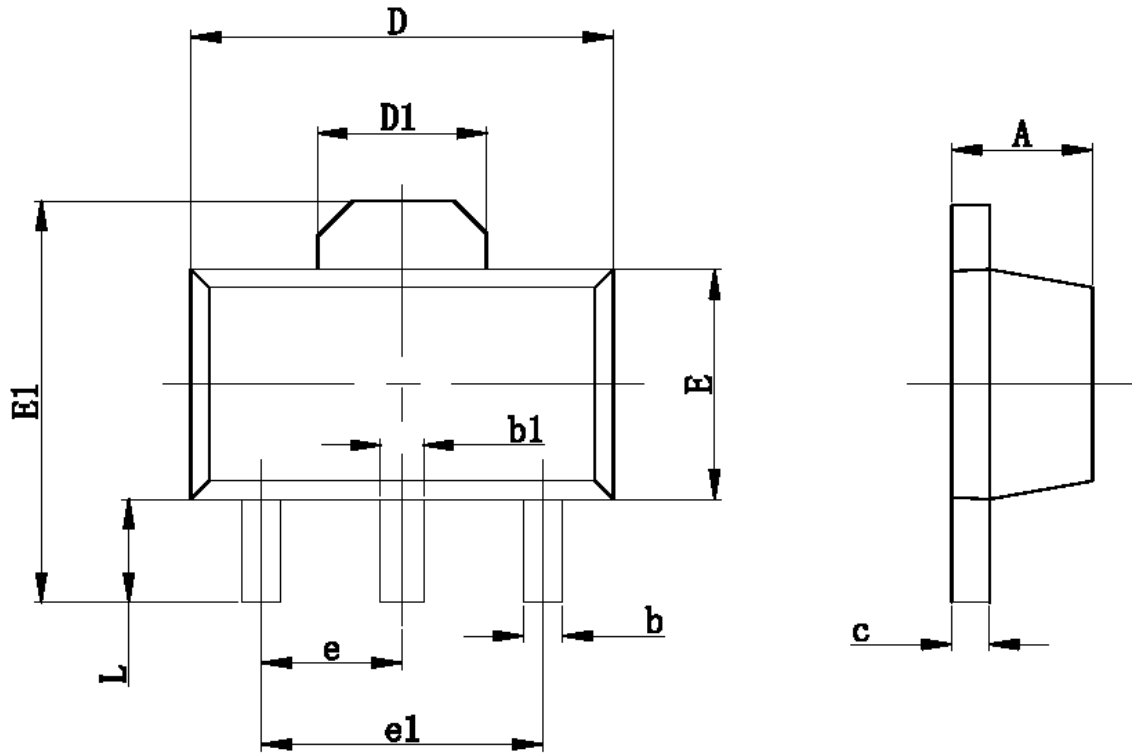

Symbol	Dimensions In Millimeters		Dimensions In Inches	
	Min	Max	Min	Max
A	1.400	1.600	0.055	0.063
b	0.320	0.520	0.013	0.197
b1	0.400	0.580	0.016	0.023
c	0.350	0.440	0.014	0.017
D	4.400	4.600	0.173	0.181
D1	1.550 REF		0.061 REF	
E	2.300	2.600	0.091	0.102
E1	3.940	4.250	0.155	0.167
e	1.500 TYP		0.060 TYP	
e1	3.000 TYP		0.118 TYP	
L	0.900	1.200	0.035	0.047

• SOT-23-5

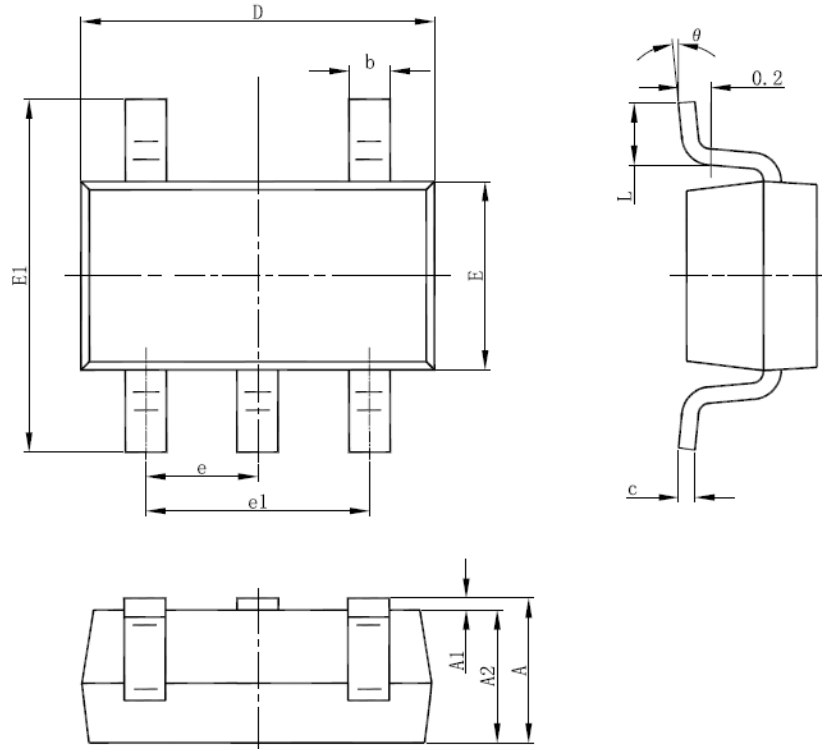

Symbol	Dimensions In Millimeters		Dimensions In Inches	
	Min	Max	Min	Max
A	1.050	1.250	0.041	0.049
A1	0.000	0.100	0.000	0.004
A2	1.050	1.150	0.041	0.045
b	0.300	0.500	0.012	0.020
c	0.100	0.200	0.004	0.008
D	2.820	3.020	0.111	0.119
E	1.500	1.700	0.059	0.067
E1	2.650	2.950	0.104	0.116
e	0.950(BSC)		0.037(BSC)	
e1	1.800	2.000	0.071	0.079
L	0.300	0.600	0.012	0.024
θ	0°	8°	0°	8°

• SOT-89-5

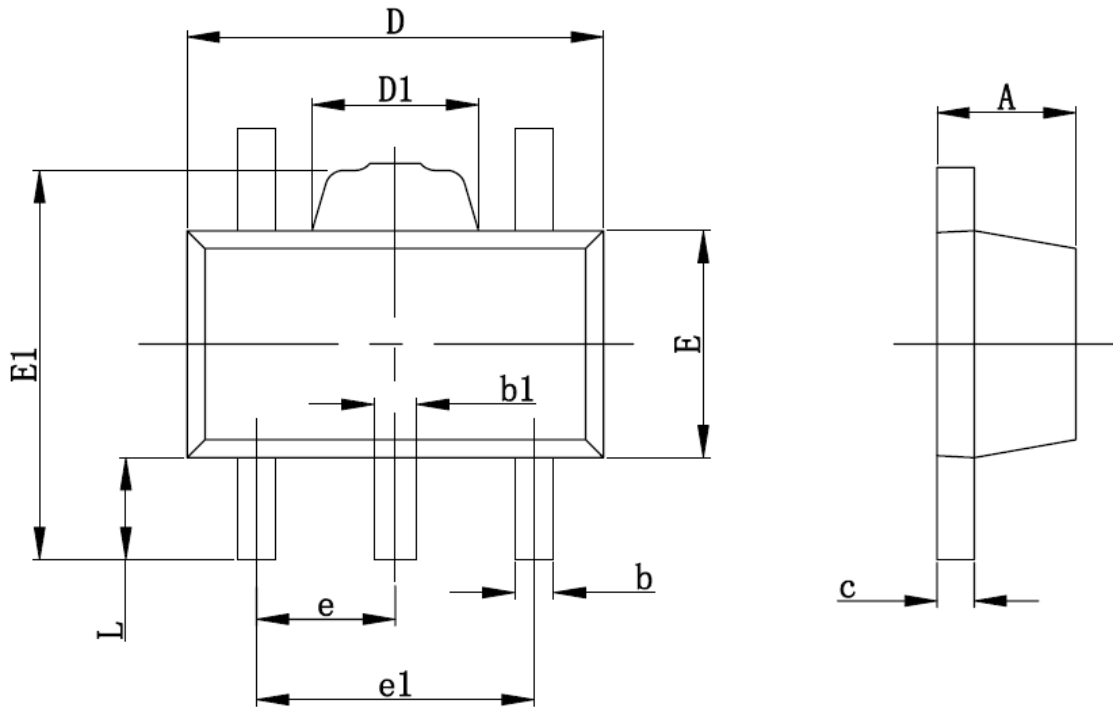

Symbol	Dimensions In Millimeters		Dimensions In Inches	
	Min	Max	Min	Max
A	1.400	1.600	0.055	0.063
b	0.320	0.520	0.013	0.020
b1	0.360	0.560	0.014	0.022
c	0.350	0.440	0.014	0.017
D	4.400	4.600	0.173	0.181
D1	1.400	1.800	0.055	0.071
E	2.300	2.600	0.091	0.102
E1	3.940	4.250	0.155	0.167
e	1.500TYP		0.060TYP	
e1	2.900	3.100	0.114	0.122
L	0.900	1.100	0.035	0.043

- TO-92

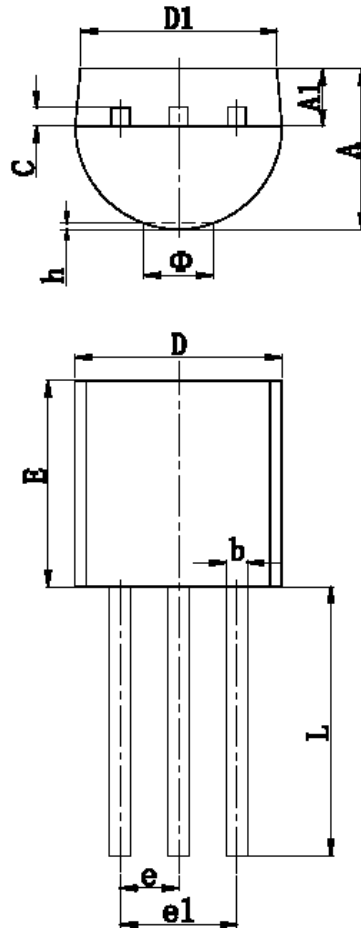

Symbol	Dimensions In Millimeters		Dimensions In Inches	
	Min	Max	Min	Max
A	3.300	3.700	0.130	0.146
A1	1.100	1.400	0.043	0.055
b	0.380	0.550	0.015	0.022
c	0.360	0.510	0.014	0.020
D	4.400	4.700	0.173	0.185
D1	3.430		0.135	
E	4.300	4.700	0.169	0.185
e	1.270 TYP		0.050 TYP	
e1	2.440	2.640	0.096	0.104
L	14.100	14.500	0.555	0.571
Φ		1.600		0.063
h	0.000	0.380	0.000	0.015