

Descriptions

The product provides a solution to an integrated brush DC motor drive circuit for battery-powered toy and low-voltage or battery-powered motion control applications. The circuit integrates on-chip H-bridge drive circuit designed with N-channel and P-channel power MOSFETs, and is suitable to drive a brush DC motor or a stepper motor winding. It has the wider operational voltage range (from 2.5V to 7.5V), its maximum continuous output current is up to 1.3A, and its maximum peak output current is up to 3.5A.

The drive circuit has a built-in overheating protection circuit. If a load current flowing through drive circuit is much higher than its maximum continuous current, then a junction temperature of on-chip circuit, limited by package heat dissipation capacity, will increase rapidly. Once the junction temperature exceeds a set value that is typically 150°C, the on-chip circuit will switch off output power transistor and cut off load current so as to prevent temperature from increasing continuously, causing potential safety hazards such as plastic package smoking, firing. On-chip temperature hysteresis circuit ensures that circuit re-control is not allowed until after the circuit returns to safety temperature.

The drive circuit has a built-in current protection circuit. If the current flowing through power transistor exceeds a set value, then the built-in current protection circuit will be turned on and the maximum output current of power transistor will be limited to the set value. The function ensures that the circuit won't be burnt down if an output port and a ground are short-circuited, or if an output port and an output port are short-circuited.

Features

- Low standby current (less than 2uA);
- Low static operating current;
- Integrated H-bridge drive circuit;
- Built-in anti-common mode switching-on circuit;
- Low on-resistance power MOSFET
- On-chip thermal shut-down (TSD) protection with hysteresis;
- Built-in current protection circuit, output-ground and output-output short-circuit, no circuit is burnt down;
- Anti-static grade: 3KV (HBM)

Typical applications

- Toy motor drive with 2-4 AA/AAA dry cells;
- Toy motor drive with 2-4 Ni-H or Ni-Cd rechargeable batteries;
- Toy motor drive with 1 lithium-ion battery.
- Electric lock and other electronic equipment driver

Ordering guide

Product model	Package
HG40F13	SOP-8

Pin Assignment

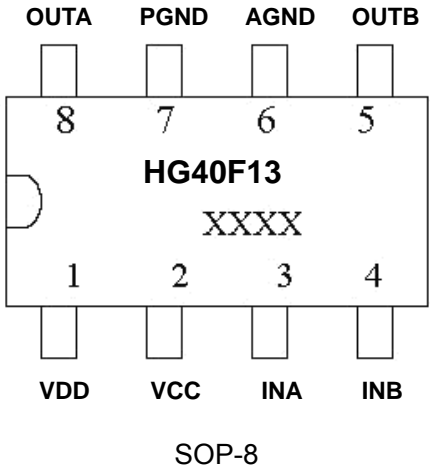
				<table border="1"> <thead> <tr> <th>No</th> <th>Mnemonic</th> <th>I/O</th> <th>Pin Function Description</th> </tr> </thead> <tbody> <tr> <td>1</td> <td>VDD</td> <td>--</td> <td>Power supply</td> </tr> <tr> <td>2</td> <td>VCC</td> <td>--</td> <td>Power supply of logic circuit</td> </tr> <tr> <td>3</td> <td>INA</td> <td>I</td> <td>Forward rotation logic input</td> </tr> <tr> <td>4</td> <td>INB</td> <td>I</td> <td>Backward rotation logic input</td> </tr> <tr> <td>5</td> <td>OUTB</td> <td>O</td> <td>Backward rotation output</td> </tr> <tr> <td>6</td> <td>AGND</td> <td>--</td> <td>Ground of logic control circuit</td> </tr> <tr> <td>7</td> <td>PGND</td> <td>--</td> <td>Ground of output power</td> </tr> <tr> <td>8</td> <td>OUTA</td> <td>O</td> <td>Forward rotation output</td> </tr> </tbody> </table>	No	Mnemonic	I/O	Pin Function Description	1	VDD	--	Power supply	2	VCC	--	Power supply of logic circuit	3	INA	I	Forward rotation logic input	4	INB	I	Backward rotation logic input	5	OUTB	O	Backward rotation output	6	AGND	--	Ground of logic control circuit	7	PGND	--	Ground of output power	8	OUTA	O	Forward rotation output
No	Mnemonic	I/O	Pin Function Description																																					
1	VDD	--	Power supply																																					
2	VCC	--	Power supply of logic circuit																																					
3	INA	I	Forward rotation logic input																																					
4	INB	I	Backward rotation logic input																																					
5	OUTB	O	Backward rotation output																																					
6	AGND	--	Ground of logic control circuit																																					
7	PGND	--	Ground of output power																																					
8	OUTA	O	Forward rotation output																																					

FUNCTIONAL BLOCK DIAGRAM

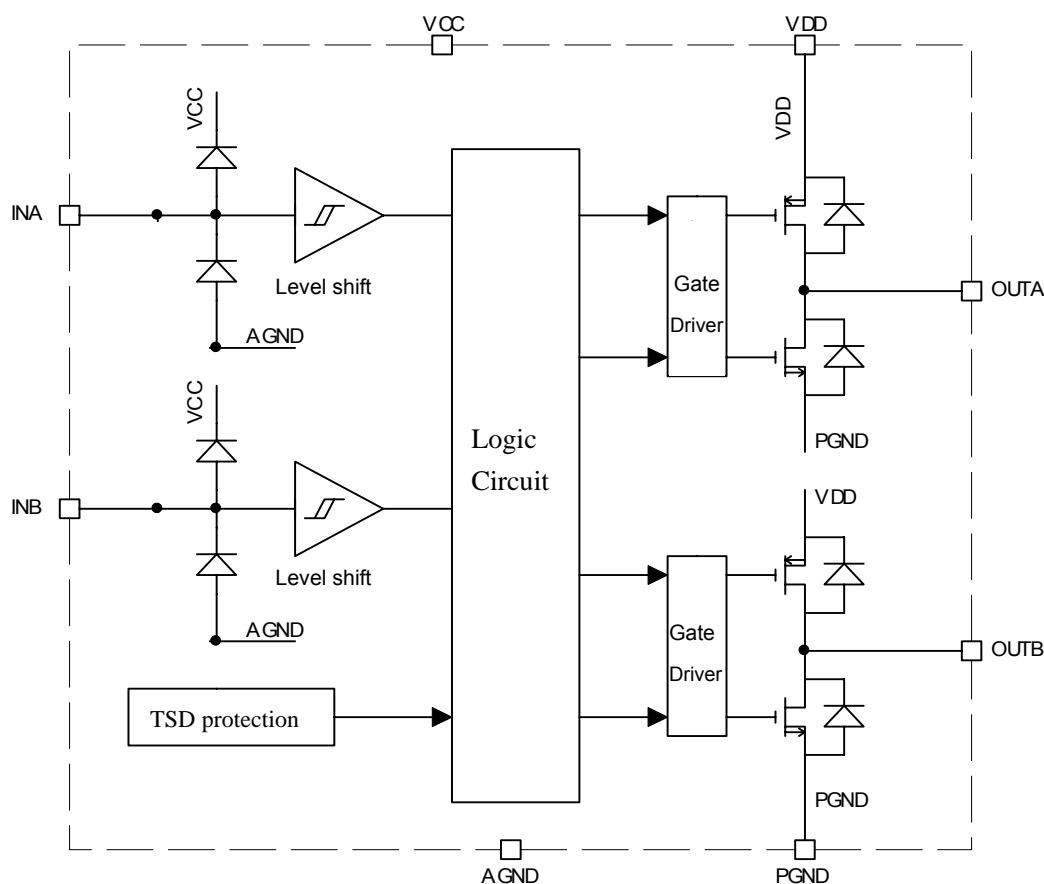

Logic truth table

INA(3pin)	INB(4pin)	OUTA(8pin)	OUTB(5pin)	Function
H	L	H	L	Forward
L	H	L	H	Backward
H	H	L	L	Brake
L	L	OPEN	OPEN	Stand-by(Stop)

Pins Waveforms

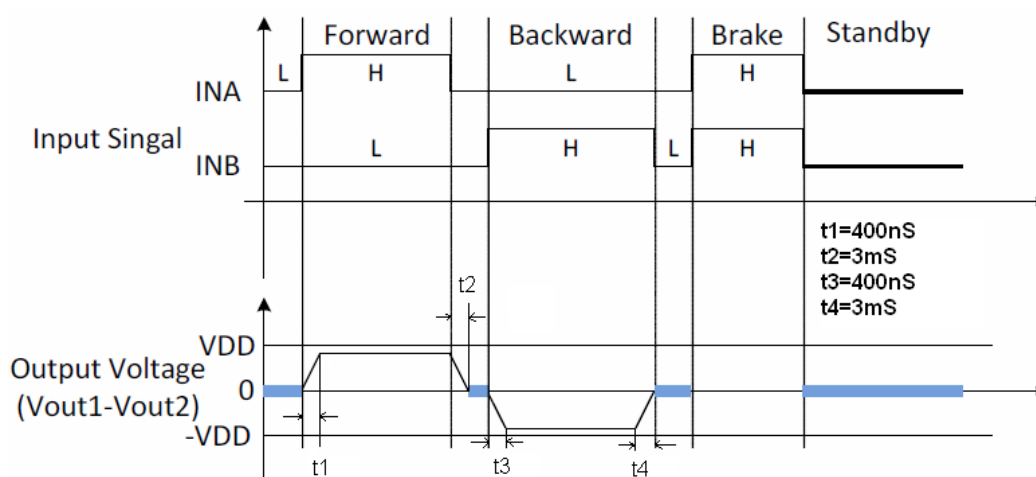

Absolute Maximum Rating (Ta=25°C)

Parameter	Symbol	Rating	Unit
Maximum supply voltage	VDD (MAX)	9.0	V
Maximum logic and control supply voltage	VCC (MAX)	6	V
Maximum output voltage	VOUT (MAX)	5.9	V
Maximum input voltage	VIN (MAX)	6	V
Peak output current	IOUT (MAX)	3.5	A
Power dissipation(SOP)	PD	1.0 (Note1,2)	W
Operating Temperature	Topr	-25 ~ +85	°C
Junction temperature	TJ	150	°C
Storage temperature	Tstg	-55 ~ +150	°C
Thermal shutdown temperature	TSD	130	°C
ESD Susceptibility	HBM	2	KV
	MM	200	V

Noted:

1. Stress beyond those listed under “Absolute maximum ratings” may cause permanent damage to the device. Exposure to absolute maximum rating conditions for extended periods may affect device reliability.
2. The accuracy of θ_{JA} or power dissipation will be based on PCB board layout.
3. Device are ESD sensitive. Handling precaution recommended. The Human Body model is 100pF capacitor discharged through a 1.5K Ω resistor into each pin.

Recommended operational conditions (Ta=25°C)

Parameter	Symbol	Min	Typ	Max	Unit
Power operation voltage (*1)	VDD	2.5	--	7.5	V
Logic supply voltage	VCC	1.8	--	5.0	V
No-load operating current (*2)	I _{OPR}	--	0.3	1.0	mA
Continuous Output Current (*3)	I _{OUT}	--	1.3	2.5	A

Noted: 1. Operature voltage under VDD=6V, I_{out}=1.3A test standard.

2. No-load current test by VDD=6V, V_{in}=3V.

3. Continuous output current will be based on PCB board layout. PCB size: 18.5mm*31.5mm.

Electrical Characteristics: (Ta=25°C, VDD=6V, V_{in}=3V, unless otherwise specified)

Parameter	Symbol	Condition	Min	Typ	Max	Unit
Power parameters						
Quiescent Current	I _s	VDD=6V, V _{in} =0V			2	uA
VDD static supply current	I	VDD=6V, V _{in} =H, without output	--	0.1	1	mA
Input logic level						
Input high level ①	V _{INH}	VDD=6V, I _{out} =1.2A	2.0	--	VCC	V
Input low level ②	V _{INL}	VDD=6V, I _{out} =1.2A	--	--	0.9	
Input level hysteresis	V _{HYS}		--	0.6	--	
Input high current	I _{INH}	V _{INH} =3V, VDD=6V without output	--	3	8	uA
Input low current	I _{INL}	V _{INH} =2V, VDD=6V without output	--	2	8	
Output level						
Output high level	V _{OUTH}	VDD=6V, I _{out} =1.2A	5.2	5.6	6	V
Output low level	V _{OUTL}	VDD=6V, I _{out} =1.2A	--	0.3	0.5	
Power transistor on-resistance						
On-resistance	R _{ON}	I _{out} =0.2A, VDD=6V, T _A =25°C (HS+LS MOS total Ron resistance)	--	0.50	--	Ω
		I _{out} =1.2A, VDD=6V, T _A =25°C (HS+LS MOS total Ron resistance)	--	0.60	--	
Protection function parameters						
Thermal shutdown temperature	T _{SD}		--	130	--	°C
TSD hysteresis	T _{SDH}		--	30	--	

Note: ①,② input logic level high and low voltage data under normal operating conditions for reference.

Electrical characteristics curve

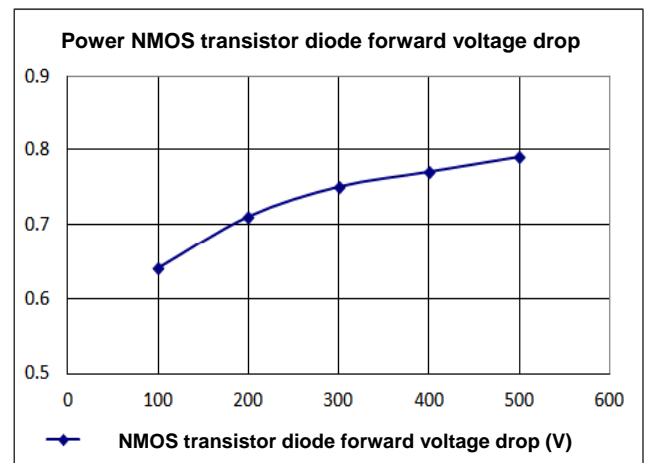
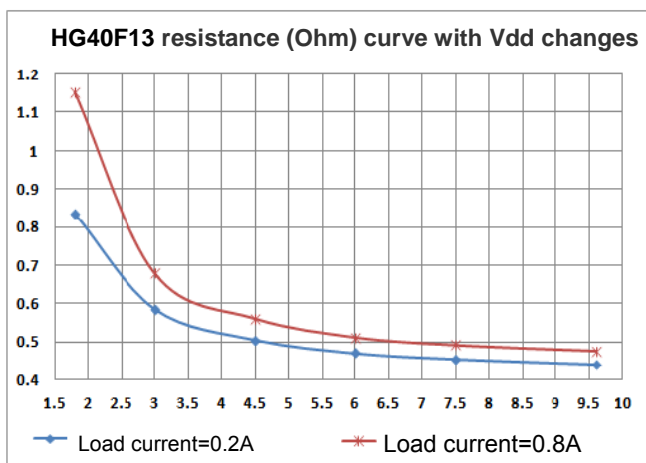
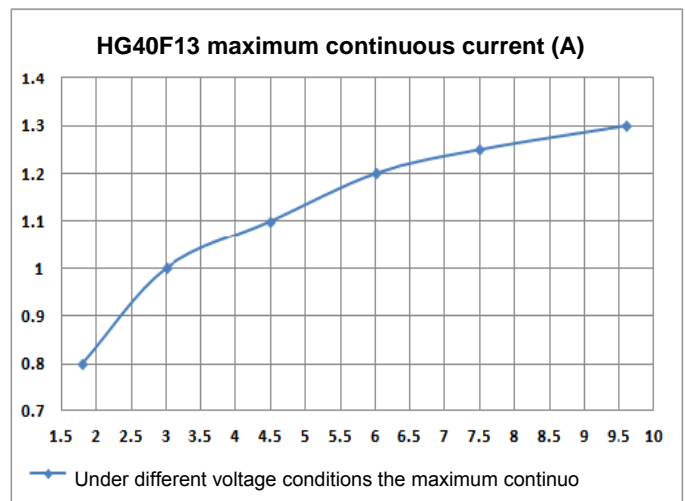
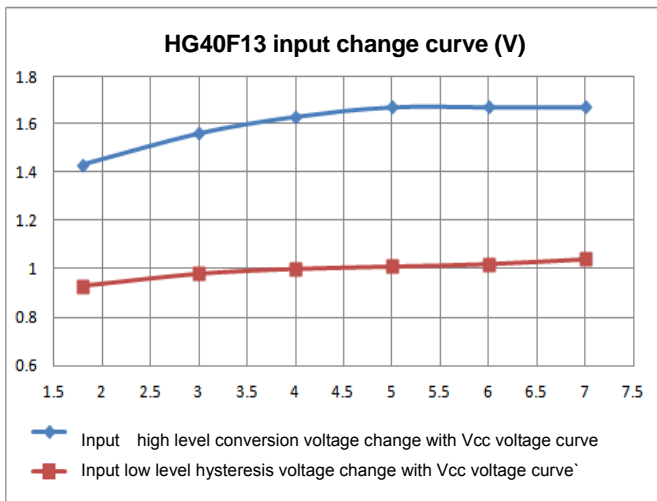
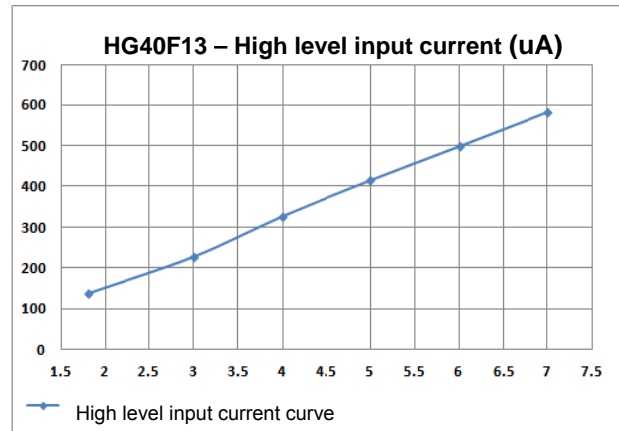
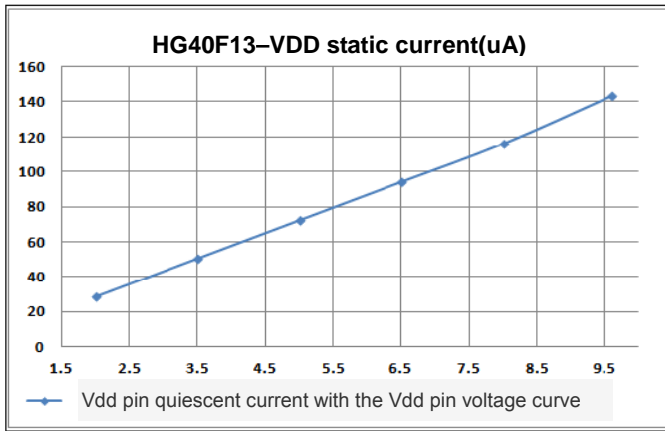

Typical application circuits

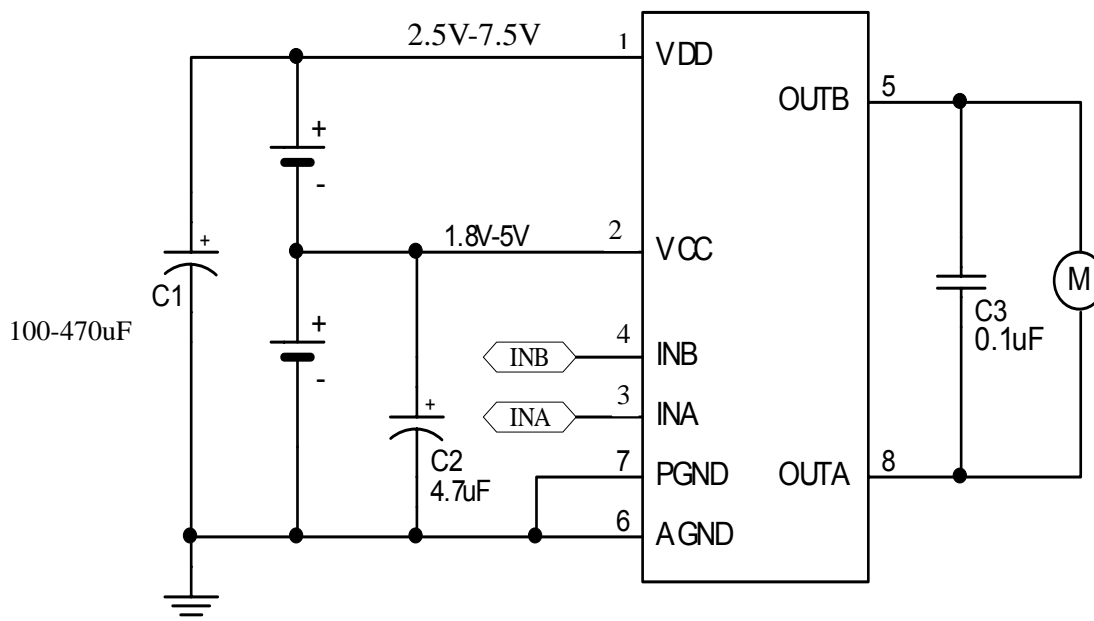

Fig.1 Schematic diagram for HG40F13 of typical application circuits

Important note:

As shown in Fig.1, the decoupling capacitance C1 from power supply VDD to ground should be adjusted based on specific applications. The higher VDD voltage is, the higher the output peak current is, the greater C1 value is. However, the capacitance C1 takes at least 4.7uF. It is recommended that C1 value should be taken as 100uF at high voltage or high current.

The capacitance C2 from logic power supply VCC to ground must be at least 4.7uF. In practice, it is unnecessary to add a capacitor separately near chip. C2 can be shared with other controlling chips such as RX2, MCU, etc. If there is not any capacitance from VCC to ground, then the circuit may get into lock state after the circuit enters overheating protection mode due to overload. After the circuit gets into lock state, the state of input signal must be changed once so that the circuit can get back to normal. As long as capacitance C2 from VCC to ground is greater than 4.7uF, the lock state of circuit will not occur.

The capacitance C3 (0.1uF) between OUTA and OUTB in Fig.1's drive circuit is the capacitance connected across the motor and doesn't need to add separate.

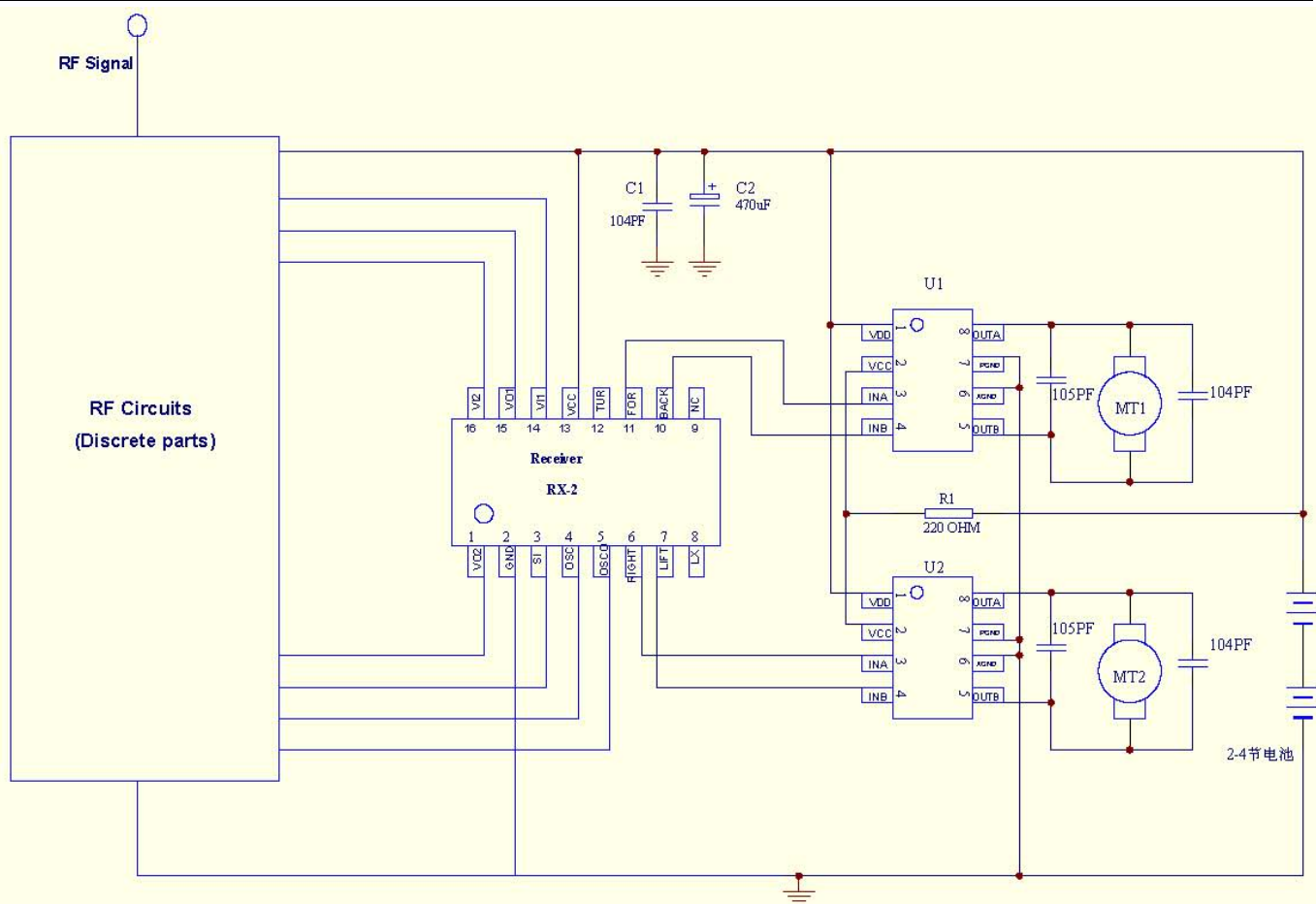

Fig.2 Schematic diagram of motor driving application circuit for 2-4 batteries operated remote control toy car

The decoupling capacitance from VDD to ground should be chosen based on practical application. The higher voltage VDD is, the higher motor current is, the greater capacitance is. The capacitance must be more than 4.7uF.

The capacitance (0.1uF) between OUTA and OUTB in Fig.2's drive circuit is the capacitance connected across the motor and doesn't need to add separate.

Application description

1、 Basic working modes

a) Standby mode

Standby mode is defined as $INA=INB=L$. All internal circuits, including drive power transistor are switched off and the circuit dissipates very low current. At the time, motor outputs OUTA and OUTB are in high impedance state.

b) Forward rotation mode

Forward rotation mode is defined as $INA=H, INB=L$. At this time, motor drive terminal OUTA outputs high level, motor drive terminal OUTB outputs low level, and motor drive current flows from OUTA into motor and from OUTB into ground. The rotation of motor at the time is defined as forward rotation mode.

c) Forward rotation mode

Backward rotation mode is defined as $INA=L$, $INB=H$. At this time, motor drive terminal OUTB outputs high level, motor drive terminal OUTA outputs low level, and motor drive current flows from OUTB into motor and from OUTA into ground. The rotation of motor at the time is defined as backward rotation mode.

d) Brake mode

Brake rotation mode is defined as $INA=H$, $INB=H$. At this time, motor drive terminals OUTA and OUTB both output low level, the energy stored in motor will be released rapidly from NMOS transistor at terminal OUTA or NMOS transistor at terminal OUTB, and motor will stop rotating in a short time. Please note that circuit will dissipates static power in brake mode.

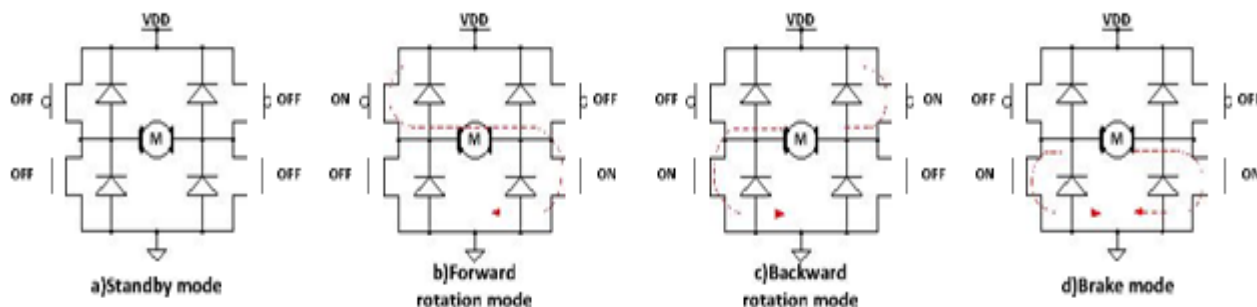

2. Anti-common mode switching-on circuit

In full-bridge drive circuit, the state where both the high-side PMOS power transistor and the low-side NMOS power transistor are switched on at the same time in half bridge is called the common-mode switching-on state. In the common-mode switching-on state there is a power-to-ground, transient, high current, which would cause an extra power loss, and, in extreme cases, would burn the circuit down. With built-in dead time, the common mode switching-on state can be avoided. The typical dead time is 300ns.

3. Overheating protection circuit

If junction temperature of drive circuit exceeds a preset temperature (150°C , typically), then TSD circuit starts to work. At this time, control circuit is forced to switch off all output power transistors, and drive circuit output gets into high-impedance state. TSD circuit is designed with thermal hysteresis. Only, if junction temperature of drive circuit decrease to a preset temperature (130°C , typically), can the circuit get back to normal operating condition.

4. Current protection circuit

A built-in comparator circuit can detect forward voltage of PMOS power transistor in real time. If forward voltage exceeds built-in set value, then the driving circuit of power transistor will drive power PMOS transistor, whose maximum output current is limited by built-in circuit, into linear constant current mode. If the junction temperature is 27°C , the maximum output current will be limited to 5A; if the junction temperature is 140°C , the maximum output current will be limited to 3.5A.

If output-ground or output-output is short-circuited, the built-in current protection circuit will protect the circuit from burning down immediately. As all the power at short-circuit is dissipated in the circuit, the temperature of circuit will go up quickly, so the circuit will enter the overheat shutoff protection mode.

Although the circuit at short-circuit does not be burnt down immediately, the life-time of chip will be affected if chip has long been short-circuited, resulting in over high built-in junction temperature.

5. Maximum continuous power dissipation of drive circuit

The motor drive circuit series is designed with on-chip overheating protection circuit. Therefore, if drive circuit dissipates too much power, then the circuit will get into thermal shut down (TSD) mode and the motor won't operate normally in thermal shutdown (TSD) mode. The formula of maximum continuous power consumption of drive circuit can be expressed as:

$$PM=(150^{\circ}\text{C}-T_A)/\theta_{JA}$$

Where 150°C is a preset temperature point for TSD circuit, T_A is an ambient temperature in $^{\circ}\text{C}$, and θ_{JA} is a junction-to-ambient thermal resistance of circuit in $^{\circ}\text{C}/\text{W}$.

Note that the maximum continuous power consumption of drive circuit is related with factors such as ambient temperature, package type, heat radiation design, but isn't related directly with internal on-resistance of circuit.

6. Power dissipation of drive circuit

Internal on-resistance of power MOSFET transistor in motor drive circuit is the primary factor that affects power dissipation of drive circuit. The formula of power dissipation of drive circuit can be expressed as:

$$PD=I_L^2 * R_{ON}$$

Where I_L is continuous output current and R_{ON} is power MOSFET on-resistance.

It should be noted that power MOSFET on-resistance will increase with increasing temperature and that, if maximum continuous output current and power dissipation of circuit are calculated, the temperature performance of internal on-resistance must be considered.

7. Maximum continuous output current of drive circuit

From maximum continuous power dissipation of drive circuit and power dissipation of drive circuit, maximum continuous output current of drive circuit can be obtained. Formula is as follows.

$$I_L = \sqrt{(150 - T_A) / (\theta_{JA} * R_{ONT})}$$

Where R_{ONT} is power MOSFET on-resistance with the temperature performance considered.

Note that maximum continuous output current of drive circuit is related to factors such as ambient temperature, package type, heat radiation design, and power MOSFET on-resistance.

8. Selection of the motor on-resistance

It can be seen from the above analysis that maximum continuous power dissipation of motor drive circuit is limited. If the motor on-resistance driven by circuit is very low, and if blocked motor current exceeds maximum continuous output current which can be taken by motor drive circuit too much, then motor drive circuit will enter overheating shut down state easily, and toy car will jitter in running or going back and forth repeatedly. Therefore, when motor drive circuit is chosen, it is necessary to consider the motor on-resistance.

Special notes

1. Reversal between power supply and ground

Reversal or reverse connection between power supply and ground will cause the circuit to damage, and, when it is serious, cause a plastic package to smoke. It is considerable to connect a power Schottky diode in series between the circuit positive terminal VDD and the battery positive terminal in order to avoid circuit damage due to battery reversal. Maximum continuous current of power Schottky diode must be greater than the continuous current with motor blocked; otherwise the Schottky diode will damage owing to overheating. Reverse breakdown voltage of power Schottky diode must be greater than maximum supply voltage. If the reverse breakdown voltage is too low, then the Schottky diode, when battery is reversed, would be broken down, thus resulting in being burnt down.

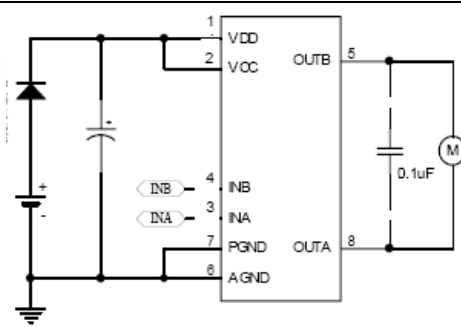

2. Power supply VDD-to-ground decoupling capacitor C1

Drive circuit requires that power supply VDD-to-ground decoupling capacitor C1 (refer to Fig.1) has mainly two functions: 1) to absorb the energy motor releases power supply in order to stabilize supply voltage and prevent circuit from being broken down due to overvoltage; 2) At the moment that motor starts or switches over rapidly from forward rotation to backward rotation or vice versa, motor needs momentary high current in order to start quickly. Due to the battery response speed and the longer connection wire, momentary high current is usually not immediately obtainable. At this time, it is necessary to rely on energy storage capacitor near motor drive circuit to release a momentary high current.

According to energy storage performance of capacitor, the greater capacitance is the smaller voltage fluctuates in the same period of time. Therefore, in the use of high-voltage, high-current, the recommendation is made that capacitance C1 be taken as 100uF. Capacitance should be chosen based on concrete applications. Capacitance C1, however, takes at least 4.7uF.

3. Static discharge protection

Input/output port of circuit uses CMOS device, and is sensitive to static discharge. Although our IC is designed with static discharge protection circuit, measures of HG40F13 static discharge protection should be taken in the course of transportation, packaging, processing, and storage, especially in processing.

4. Output-to-ground short circuit, output short circuit

If high-level output and ground, in normal operational condition of circuit, are short-circuited, or if two terminals OUTA and OUTB are short-circuited, then the very high current will flow through the circuit, the very high power dissipation will occur, and the on-chip thermal shut down circuit will be triggered, thus protecting the circuit from burning immediately. However, as the overheating protection circuit only checks temperature, but not the transient current flowing through circuit, the current at output-to-ground short-circuits would be very high, resulting easily in circuit damage. So output-to-ground short-circuit should be avoided in the use of IC, In test, taking measures of limiting current could avoid similar damage.

5. Output-to-power supply short-circuit

If low-level output and power supply, in normal operational condition of circuit, are short-circuited, then IC will be easy damage.

6. Peak current much greater than rated value

If operating voltage of the circuit is close to or greater than maximum operating voltage, and if peak current is much greater than absolute maximum peak current, then chip would burn down as well.

